



Multipole connectors

20
19



THE TRADITION OF INNOVATION SINCE 1945

ILME designs and manufactures complete solutions for industrial connections.

Headquartered in Milan and with subsidiaries in the key countries driving the progress of automation, ILME is an industry leader in the main world markets.

People are vital to success and growth at ILME, sharing a passion for innovation, utmost responsibility and participation.

The Company is committed to developing technology in the areas that most impact the future of the industries it serves: high quality and safe cabling, research on the most suitable materials, rapid turnaround and readily available services while striving for energy saving and environmental safeguard.

COMMITMENT TO INDUSTRY

Technological innovation is the main pillar of ILME competitiveness.

In the electrical connection sector of industrial automation, characterized by the need for top performance and reliability, ILME is an acknowledged leader with its own patents and a global benchmark supplier of major companies worldwide.

ILME offers a fully integrated range of high-quality products and services for every type of connection to suit any application requirements.



AUTOMATION



RAILWAY



ENERGY



NAVAL



FOOD
& BEVERAGE



AGRONOMY



OUTDOOR



TRANSPORT



LIGHT
& SOUND



PLASTIC



CHEMICAL



AIRPORT

IMPORTANT NOTES

Strictly tied to our general conditions of sales

- 1 ILME designs and manufactures complete solutions for Heavy Duty electrical power connections.
The connector (although offered to the user as a variety of elements, usually inserts and enclosures, to allow the selection of the ideal combination) has been **designed as a complete connector** and tested to be compliant with the essential safety requirements of the EU Low Voltage Directive 2006/95/EC (2014/35/EU from April 20, 2016) and in particular the EN 61984 standard. The design of this “whole” system guarantees that every allowed combination of inserts, enclosures and accessories cannot result as improper.

- 2 The products in this catalogue alone cannot guarantee the best functionality upon installation, as this depends also on their correct **“putting into service”** which must be performed in compliance with the applicable system safety standards and according to the “rule of the art”. Therefore the effectiveness of the installation of the connector depends on the choices of the end user who must also take into account the following safety requirements.

- 3 Connectors must **not be connected or disconnected when live or under load**.

- 4 After wiring the inserts it is necessary to **verify the continuity of the protective earth connections**.

- 5 The **correct coupling of the inserts** is guaranteed only if they are installed (with the four fixing screws supplied*) inside the corresponding enclosures or onto compatible accessories in this catalogue. ILME S.p.A. is not responsible for any different application.

- 6 Wiring of **screw-type terminal connections** must be carried out applying the correct tightening torque in order to avoid false contacts or damage to the conductor, the screw or the terminal.

- 7 **Crimping tools** and **crimp contacts** used should preferably be supplied by the same manufacturer to avoid difficulties with the insertion and retention or damaging of the contacts themselves.

- 8 Correct wiring of **spring-clamp connection inserts** is guaranteed only when the correct screwdriver indicated in the specific catalogue, or possibly on the insert, is used**.

- 9 Avoid forcing the contacts during **connection and disconnection**. Connectors must be coupled and uncoupled in the axial direction with respect to the contacts, without bending and pulling the attached conductor bundles or cables.

- 10 Installation of two **inserts side by side**, in enclosures with two bays, must respect the polarity drawing marked on the insert (or the contact side view, as shown in this catalogue) to avoid inverted coupling.

- 11 Installation of two or more identical **connectors side by side** is recommended only with the use of **coding pins** in order to avoid mismatched couplings.

- 12 In order to keep the declared **degree of protection** (IP code according to EN 60529, or Enclosure Type Rating according to ANSI/UL 50E), enclosures must be completed with cable glands and/or other accessories with at least an equal degree of protection.

- 13 Moreover, the declared **degree of protection** (IP code according to EN 60529, or Enclosure Type Rating according to ANSI/UL 50E) is guaranteed when the enclosures, complete with inserts, are coupled and locked with their locking levers (or devices).

- 14 Connector inserts and their enclosures are generally compatible with similar/equivalent products from other manufacturers, according to the last samples tested. Full compatibility cannot be guaranteed in the event of technical changes made by other manufacturers. In particular, maximum performance of IP68 enclosures (CG Series) cannot be guaranteed when coupled with other manufacturers’ products.

- 15 **Spare parts** are supplied in minimum quantities only with the purpose to replace damaged parts. To avoid invalidation of warranty, products should be modified or repaired only by ILME: the integrity of their functionality - e.g. their degree of protection - can no longer be guaranteed if products are modified/repared by end-users. In any case, the liability for correct choice, assembly and use is totally at charge of the installer and the end-user.

- 16 ILME S.p.A. takes no responsibility in verifying whether the components herein contained comply with any specific regulations of fields of application.

- 17 Finally, Please note:
 - ILME cannot be held responsible for individual components in **uses other than those described in this catalogue**.
 - ILME cannot be held responsible for **incorrect connector selection** in relation to the environmental conditions of the application (e.g.: influence of ambient temperature, moisture, environmental pollution, etc.).

* Except one fixing screw for size “21.21” inserts, two fixing screws for size “32.13” inserts.

** Except for **Squich®** inserts (with spring-clamp terminals with actuator button) that do not require any tool to operate the terminal.

CE MARKING

As from 1st January 1997, in order to make available electrical products on the European market, the manufacturer must ensure that these bear the relevant **CE marking**, in line with the Low Voltage Directive 73/23/EEC* (implemented in Italy as L. D. 18-10-1977 no. 791) and its modification 93/68/EEC* (implemented in Italy as L.D. 25-11-1996 no. 626/96, published in the supplement to the Gazzetta Ufficiale of 14-12-1996).

The CE marking must be visible on the product or, if this is not possible, on the packaging, the instructions for use or on the warranty certificate. It acts as a declaration by the manufacturer that the product complies with all relevant EU directives regarding its field of application.

ILME products bear the CE marking on the actual product or its packaging.

Almost all ILME products fall within the scope of the Low Voltage Directive. An EU declaration of conformity is required in order to be able to apply the CE marking. This declaration, to which the market is not directly entitled, must be made available to the controlling authorities (in Italy, the Ministry of Economic Development) at all times. In it, the manufacturer declares the technical safety standard(s) followed in the design and manufacture of the product. These standards must be, in decreasing order of preference:

- a European standard (EN prefix)
- a European harmonisation document (HD prefix)
- an international IEC standard
- a national standard
- in the absence of reference standards, the manufacturer's internal specifications guaranteeing compliance with the basic safety requirements of the directive.

Conformity with harmonised technical standards (i.e. ratified by CENELEC) also constitutes presumption of conformity with the basic safety requirements of the directives.

The CE marking of ILME products results from the declaration of conformity of the product to harmonised standards or international IEC standards.

Through the CE marking, ILME declares full compliance, not merely with the directive's basic safety requirements, but also with those international or national standards on which voluntary safety certification markings are based (e.g. IMQ and VDE). In this way, ILME intends to give the CE marking the value of self-certification in terms of safety, given the loss in legal value of voluntary certifications issued by third parties, ratified by directive 93/68/EEC*.

Notwithstanding the above, practically all ILME products still bear voluntary conformity markings.

The above mentioned EU declaration of conformity becomes null and void when the assembly of products includes one or more components not manufactured by ILME and without CE marking.

▲ The information contained in this catalogue is not binding and may be changed without notice.

* **Note:** The next legal reference for the Low Voltage Directive was 2006/95/EC, as consolidation of the original Directive 73/23/EEC + Directive 93/68/EEC. On 29th March 2014, the Official Journal of the European Union published the new Low Voltage directive 2014/35/EU dd. 26th February 2014, a recast version of directive 2006/95/EC, which is in force since 20th April 2016.



UNI EN ISO 9001: 2015
Design, manufacture and distribution
of industrial electrical equipment (IAF 19)
Certificate No. 50 100 11133

2019 PRODUCTS

Inserts

14

CSH SQUICH® INSERT "S" VERSION

14

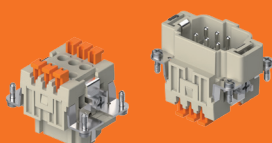

CSHF/M 06 S, CSHF/M 10 S
CSHF/M 16 S (16 SN), CSHF/M 24 S (24 SN)
Technical features

15-21

JSH SQUICH® INSERT "S" VERSION

22

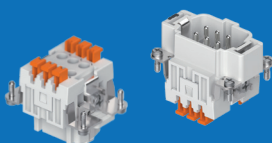

JSHF/M 06 S, JSHF/M 10 S
JSHF/M 16 S (16 SN), JSHF/M 24 S (24 SN)
Technical features

23-29

CQ SERIES

30



CQ4F/M 02
CQ4F/M 02 H
Technical features

31-35

HNM RX SERIES - HIGH NUMBER OF MATINGS

36

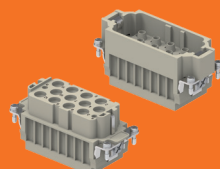

RXF/M 12/2
Technical features

37-39

MIXO modular units **40**

MIXO SERIES **40**
THE COMPLETE RANGE OF MODULES **41**

SQUICH® SERIES **42**

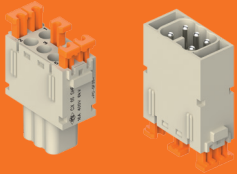

CX 05 SHF/SHM **42**
Technical features **43 - 45**

CX SERIES **46**

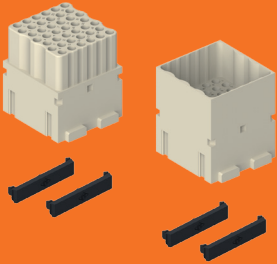

CX 42 DF/DM **46**
Technical features **47 - 51**

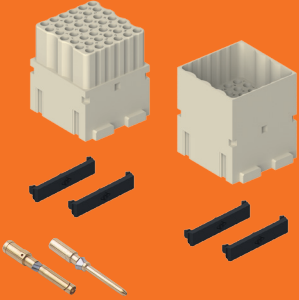

**CX 42 DF/DM
HNM VERSION** **50**

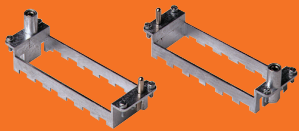

HNM MIXO FRAMES **51**

Enclosures 52

MIXO ONE ENCLOSURES 52

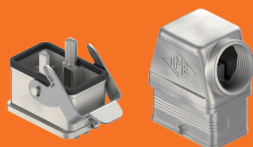

CXA - MXA SINGLE MODULE
 Technical features 53-57

MKA IF METAL HOUSINGS size "21.21" 58

Main features 59

C-TYPE STANDARD METALLIC VERSION



MKAX IF
 Technical features 60



MKA IF - MKAXX IF
 Technical features 61

W-TYPE FOR AGGRESSIVE ENVIRONMENTS



MKAXW IF
 Technical features 62



MKAXXW IF
 Technical features 63

EMC VERSION FOR ELECTROMAGNETIC COMPATIBILITY



MKAXS IF
 Technical features 64



MKAS IF - MKAXXS IF
 Technical features 65

180 °C VERSION FOR HIGH TEMPERATURES



MKAXR IF
 Technical features 66



MKAXXR IF
 Technical features 67

**MKAS IVG20 EMC VERSION size "21.21"
FOR ELECTROMAGNETIC COMPATIBILITY**

68

Main features

69



MKAXS

Technical features

70



MKAS - MKAXXS

Technical features

71

M25 INSULATING HOODS MK - MKG size "21.21"

72

Main features

73



MK - MKG

Technical features

74 - 75



MK - MKG

Technical features

76- 77

MKA VG25 METAL HOODS M25 CABLE ENTRY

78

Main features

79

C-TYPE STANDARD METALLIC VERSION



MKAX

Technical features

80



MKA - MKAXX

Technical features

81

W-TYPE FOR AGGRESSIVE ENVIRONMENTS



MKAXW VG25

Technical features

82



MKAXXW VG25

Technical features

83

EMC VERSION FOR ELECTROMAGNETIC COMPATIBILITY



MKAXS IF

Technical features

84



MKAS IF - MKAXXS IF

Technical features

85

M25 METAL HOODS - IP68 HIGH PROTECTION

MGK V25, MGK V25 B

86

Main features

87



MGK

Technical features

88

MGK B

Technical features

89

HOODS WITH PEGS FOR CENTRAL LEVER

CAV/MAV GYC, CFV/MFV GYC

90

Main features

91



CA - MA / CF - MF

Technical features

92 - 95

SIZE "77.62" HOUSINGS

WITH SINGLE STAINLESS STEEL RIGID LEVER

96

Main features

97



CHIX - CHPX

Technical features

98 - 99

SURFACE MOUNTING HOUSINGS

WITH SIMPLEX SELF-CLOSING HINGED COVER

100

Main features

101



CV - CVA / MVP - MVAP

Technical features

102 - 105

CZ - MZ / CZA - MZA

Technical features

106 - 107

Accessories

108

LOCKING DEVICE FOR "CLASS" LOCKING LEVERS

108



CR CLK
Technical features

109 - 111

LOCKING DEVICE FOR ENCLOSURE SIZE "104.27" WITH CENTRAL LEVER

112

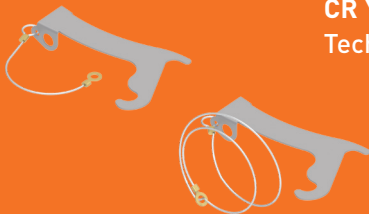

CR YLK24 - CR YLK24 SL
Technical features

113 - 115

ANCHORAGES FOR MIXO FRAMES

116



CR 16 SSD - CR 24 SSD
Technical features

117 - 119

PE TERMINAL ADAPTERS FOR MIXO FRAMES

120



CGT 6.0 - 10 - 16 - 25
Technical features

121 - 123

RJ45 UNIVERSAL PATCH CORD ADAPTER

124

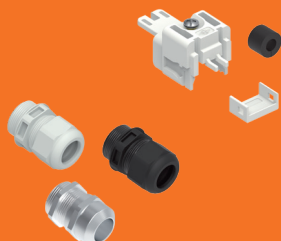

Technical features

125 - 127

HYGIENIC CABLE GLANDS

128

**AH M25IF(L) - AH M32IF(L)**
Technical features

129 - 131

Part numbers index

132

CSHF/M SQUICH® INSERTS "S" VERSION (06, 10, 16, 24, 32, 48 poles)

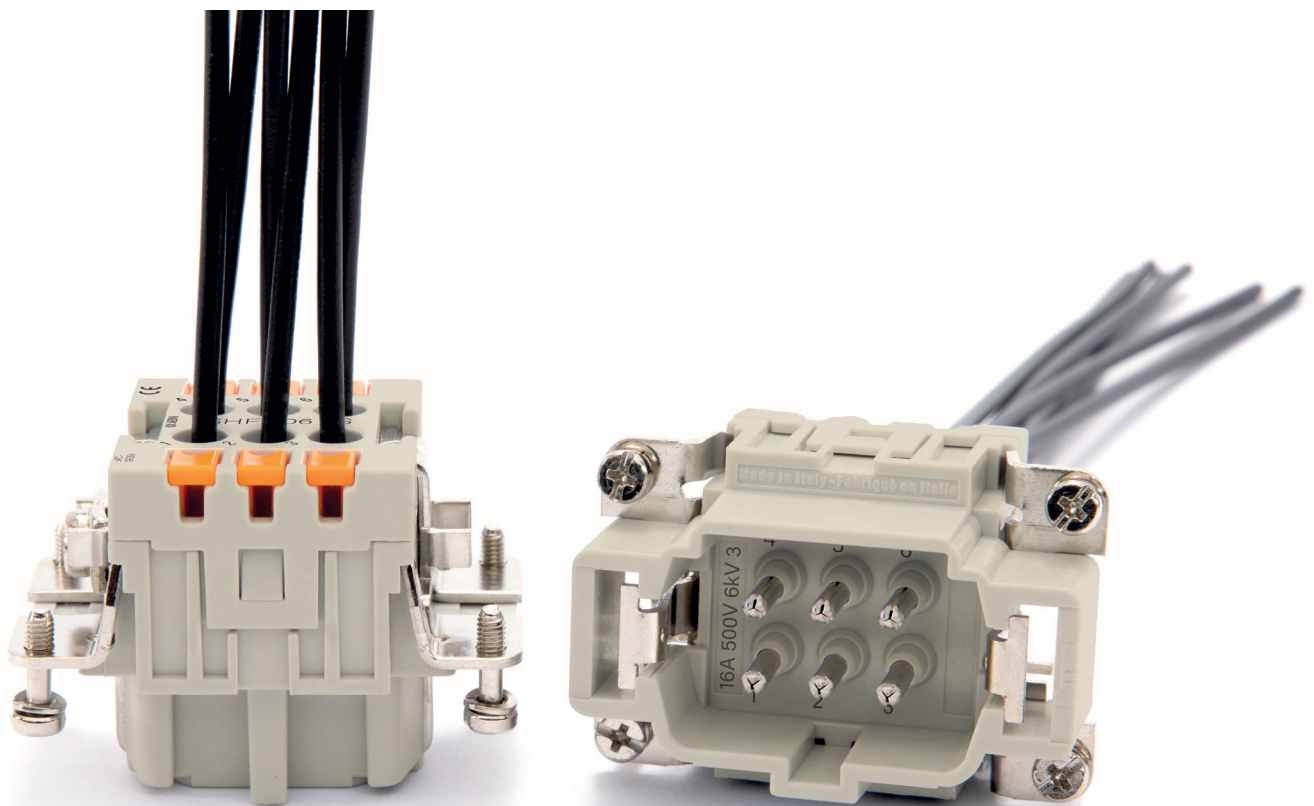

CSH S inserts series
with actuator button,
now with stamped
silver-plated contacts



Find more
information on
our products at
www.ilme.com

TECHNICAL FEATURES

CSHF/M 06, 10, 16 (16 SN), 24 (24 SN) S

Demand for cost-effective solutions for large serial production is constantly growing and stamped contacts meet the basic needs for such applications.

- **Silver plating** of the contacts, suitable for up to **500 mating cycles**;



- features all the well-known **advantages of the SQUICH®** proprietary technology:

- **reduced wiring time** (spring-clamp terminals are presented "open", with the actuator button lifted up); up to **50% saving time** compared to screw connection;
- **operator skill independence** (no need to open the spring-clamp terminals by direct operation of a possibly unsuitable tool on the spring);
- **no special wire preparation** (only stripping at the correct length);
- no wiring tool needed;
- **resistance to strong vibrations** typical of the self-compensating spring-clamp technology;
- possibility **to use rigid and flexible** stranded copper conductors with range of cross sectional area between 0,14 mm² and 2,5 mm² (26 - 14 AWG);
- possibility to insert the **test probe** of a measurement instrument in the cavity of the actuator button (proprietary design);
- simple re-opening of a terminal (if needed) using a flat blade screwdriver on the actuator button dedicated side window.

new
stamped
silver-plated
contacts

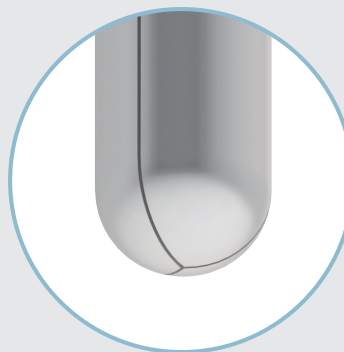
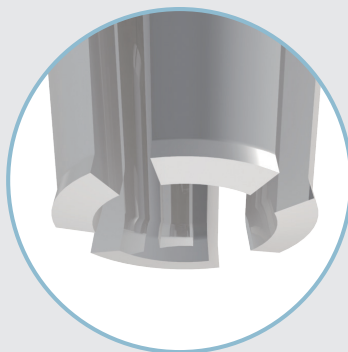

CSHF/M 06 S 6 poles + ⊕ 16A - 500V SQUICH®

enclosures: size "44.27"	page: 240-243
C-TYPE IP65/IP66	274
C7 IP67, single lever	280-284, 286
V-TYPE IP65/IP66, single lever	304-306
BIG hoods	326-327
T-TYPE IP65 insulating	336-337
T-TYPE / W IP66 insulating	350-351
HYGIENIC T-TYPE / H IP66/IP69	358-359
HYGIENIC T-TYPE / C IP66/IP69, -50 °C	373
W-TYPE for aggressive environments	392
EMC	404-405
Central lever	420-423
IP68	450-451
LS-TYPE	42-43, 55, 62-63 *
E-Xtreme® corrosion proof	page: 462-463
panel supports: COB	

* refer to NEWS 2017 pages
refer to CN.16 pages

inserts, spring terminal connections

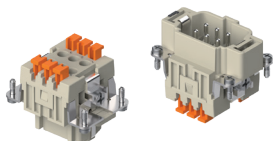

Q STAMPED CONTACTS, SILVER PLATED
FROM NOVEMBER 2019

description	part No.
-------------	----------

spring terminals with actuator button
female inserts with female contacts
male inserts with male contacts

CSHF 06 S
CSHM 06 S

- characteristics according to EN 61984:
16A 500V 6kV 3
16A 400/690V 6kV 2
- cURus, CSA, CQC, DNV-GL, BV, EAC pending
- rated voltage according to UL/CSA: 600V
- insulation resistance: $\geq 10 \text{ G}\Omega$
- ambient temperature limit: $-40 \text{ }^\circ\text{C} \dots +125 \text{ }^\circ\text{C}$
- made of self-extinguishing thermoplastic resin
UL 94V-0
- mechanical life: ≥ 500 cycles
- contact resistance: $\leq 3 \text{ m}\Omega$

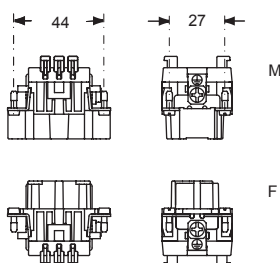

contacts side (front view)

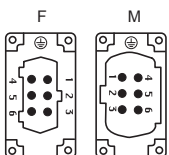

- inserts for connectors with the following conductor cross-sectional areas: 0,14 - 2,5 mm² - AWG 26 - 14
- conductors stripping length: 9...11 mm

SQUICH®-spring connection technology

CLOSING

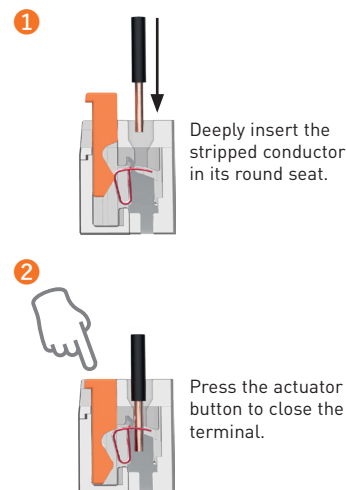

RE-OPENING

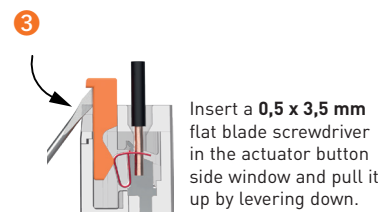

enclosures: size "57.27"	page: 244-249
C-TYPE IP65/IP66	275
C7 IP67, two levers	281-288, 291
V-TYPE IP65/IP66, single lever	308-311
BIG hoods	328-329
T-TYPE IP65 insulating	338-339
T-TYPE / W IP66 insulating	352-353
HYGIENIC T-TYPE / H IP66/IP69	360-361
HYGIENIC T-TYPE / C IP66/IP69, -50 °C	374
W-TYPE for aggressive environments	393
EMC	406-407
Central lever	424-427
IP68	452-453
LS-TYPE	44-45, 56, 64-65 *
E-Xtreme® corrosion proof	page: 462-463
panel supports: COB	

* refer to NEWS 2017 pages
refer to CN.16 pages

inserts,
spring terminal connections

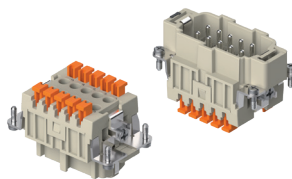

Q STAMPED CONTACTS, SILVER PLATED
FROM NOVEMBER 2019

description	part No.
-------------	----------

spring terminals with actuator button
female inserts with female contacts
male inserts with male contacts

CSHF 10 S
CSHM 10 S

- characteristics according to EN 61984:
16A 500V 6kV 3
16A 400/690V 6kV 2
- cURus, CSA, CQC, DNV-GL, BV, EAC pending
- rated voltage according to UL/CSA: 600V
- insulation resistance: $\geq 10 \text{ G}\Omega$
- ambient temperature limit: $-40 \text{ }^\circ\text{C} \dots +125 \text{ }^\circ\text{C}$
- made of self-extinguishing thermoplastic resin
UL 94V-0
- mechanical life: ≥ 500 cycles
- contact resistance: $\leq 3 \text{ m}\Omega$

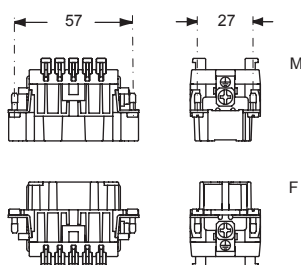

contacts side (front view)

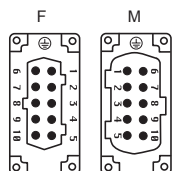

- inserts for connectors with the following conductor cross-sectional areas: $0,14 - 2,5 \text{ mm}^2$ - AWG 26 - 14
- conductors stripping length: 9...11 mm

SQUICH®-spring connection technology

CLOSING

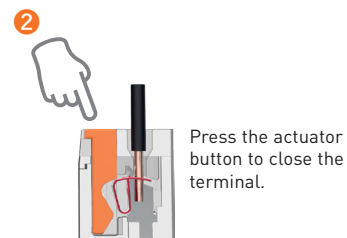
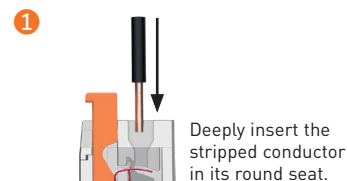

RE-OPENING

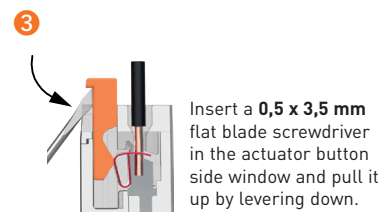

CSHF/M 16 S 16 poles + ⊕ 16A - 500V SQUICH®

enclosures: size "77.27"	page:
C-TYPE IP65/IP66	250-256
C7 IP67, two levers	276
V-TYPE IP65/IP66, single lever	282-292, 295
BIG hoods	312-315
T-TYPE IP65 insulating	330-331
T-TYPE / W IP66 insulating	340-341
HYGIENIC T-TYPE / H IP66/IP69	354-355
HYGIENIC T-TYPE / C IP66/IP69, -50 °C	362-363
W-TYPE for aggressive environments	375
EMC	394
Central lever	408-409
IP68	428-431
LS-TYPE	454-455
E-Xtreme® corrosion proof	46-47, 57, 66-67 *
panel supports: COB	page: 462-463

* refer to NEWS 2017 pages
 refer to CN.16 pages

inserts, spring terminal connections

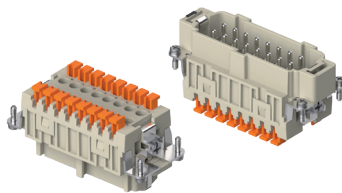

Q STAMPED CONTACTS, SILVER PLATED
FROM NOVEMBER 2019

description	part No.
-------------	----------

spring terminals with actuator button
 female inserts with female contacts
 male inserts with male contacts

CSHF 16 S
CSHM 16 S

- characteristics according to EN 61984:
16A 500V 6kV 3
16A 400/690V 6kV 2
- cURus, CSA, CQC, DNV-GL, BV, EAC pending
- rated voltage according to UL/CSA: 600V
- insulation resistance: $\geq 10 \text{ G}\Omega$
- ambient temperature limit: -40 °C ... +125 °C
- made of self-extinguishing thermoplastic resin
 UL 94V-0
- mechanical life: ≥ 500 cycles
- contact resistance: $\leq 3 \text{ m}\Omega$

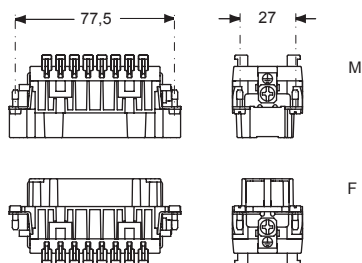

contacts side (front view)

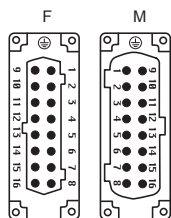

- inserts for connectors with the following conductor cross-sectional areas: 0,14 - 2,5 mm² - AWG 26 - 14
- conductors stripping length: 9...11 mm

SQUICH®-spring connection technology

CLOSING

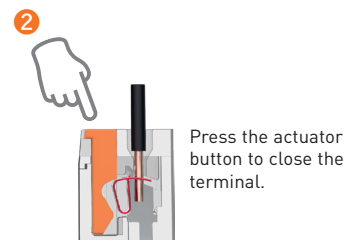
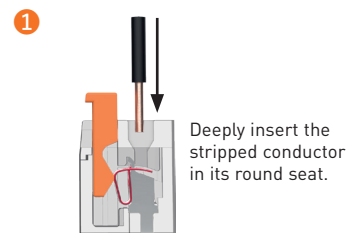

RE-OPENING

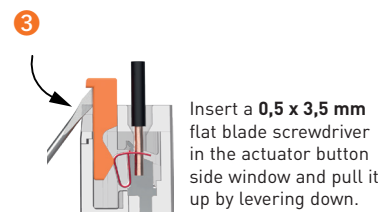

enclosures: size "104.27"	page:
C-TYPE IP65/IP66	258-266
C7 IP67, two levers	277
V-TYPE IP65/IP66, single lever	283-296, 299
BIG hoods	316-319
T-TYPE IP65 insulating	332-333
T-TYPE / W IP66 insulating	342-343
HYGIENIC T-TYPE / H IP66/IP69	356-357
HYGIENIC T-TYPE / C IP66/IP69, -50 °C	364-365
W-TYPE for aggressive environments	376
EMC	395
Central lever	410-412
IP68	432-435
LS-TYPE	456-457
E-Xtreme® corrosion proof	48-49, 58, 68-69 *
panel supports:	page:
COB	462-463

* refer to NEWS 2017 pages
 refer to CN.16 pages

inserts,
spring terminal connections

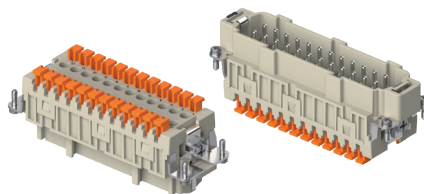

Q STAMPED CONTACTS, SILVER PLATED
 FROM NOVEMBER 2019

description

part No.

spring terminals with actuator button
 female inserts with female contacts
 male inserts with male contacts

CSHF 24 S
 CSHM 24 S

- characteristics according to EN 61984:
16A 500V 6kV 3
16A 400/690V 6kV 2
- cURus, CSA, CQC, DNV-GL, BV, EAC pending
- rated voltage according to UL/CSA: 600V
- insulation resistance: $\geq 10 \text{ G}\Omega$
- ambient temperature limit: $-40 \text{ }^\circ\text{C} \dots +125 \text{ }^\circ\text{C}$
- made of self-extinguishing thermoplastic resin
 UL 94V-0
- mechanical life: ≥ 500 cycles
- contact resistance: $\leq 3 \text{ m}\Omega$

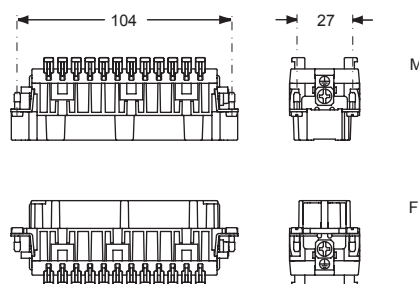

contacts side (front view)

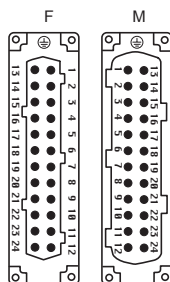

- inserts for connectors with the following conductor cross-sectional areas: $0,14 - 2,5 \text{ mm}^2$ - AWG 26 - 14
- conductors stripping length: 9...11 mm

SQUICH®-spring connection technology

CLOSING

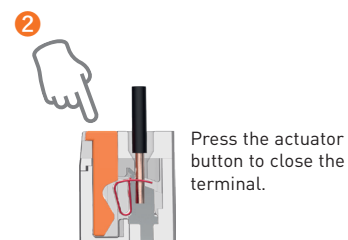
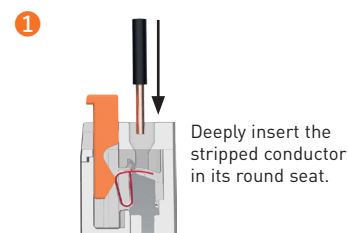

RE-OPENING

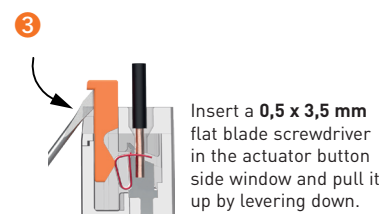

enclosures: size "77.62"	page: 250-256
C-TYPE IP65/IP66	276
C7 IP67, two levers	282-292, 295
V-TYPE IP65/IP66, single lever	312-315
BIG hoods	330-331
T-TYPE IP65 insulating	340-341
T-TYPE / W IP66 insulating	354-355
HYGIENIC T-TYPE / H IP66/IP69	362-363
HYGIENIC T-TYPE / C IP66/IP69, -50 °C	375
W-TYPE for aggressive environments	394
EMC	408-409
Central lever	428-431
IP68	454-455
LS-TYPE	57, 66-67 *
E-Xtreme® corrosion proof	page: 462-463
panel supports: COB	

* refer to NEWS 2017 pages
 refer to CN.16 pages

inserts,
spring terminal connections

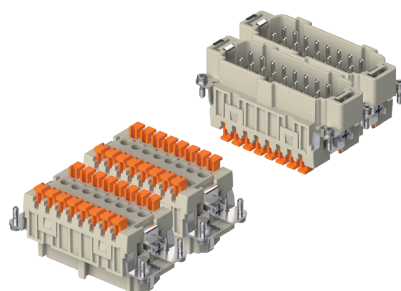

Q STAMPED CONTACTS, SILVER PLATED
FROM NOVEMBER 2019

description	part No.	part No.
-------------	----------	----------

spring terminals with actuator button
 female inserts with female contacts, No. (1-16) & (17-32)
 male inserts with male contacts, No. (1-16) & (17-32)

CSHF 16 S	CSHF 16 SN
CSHM 16 S	CSHM 16 SN

- characteristics according to EN 61984:
16A 500V 6kV 3
16A 400/690V 6kV 2
- cURus, CSA, CQC, DNV-GL, BV, EAC pending
- rated voltage according to UL/CSA: 600V
- insulation resistance: ≥ 10 GΩ
- ambient temperature limit: -40 °C ... +125 °C
- made of self-extinguishing thermoplastic resin
 UL 94V-0
- mechanical life: ≥ 500 cycles
- contact resistance: ≤ 3 mΩ

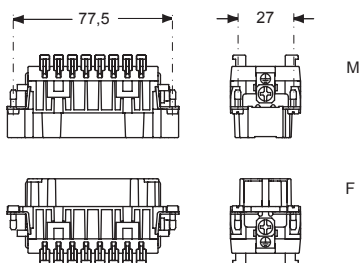

contacts side (front view)

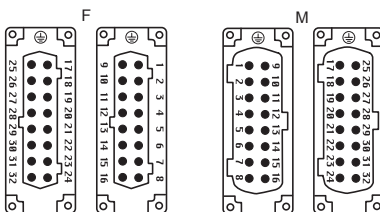

- inserts for connectors with the following conductor cross-sectional areas: 0,14 - 2,5 mm² - AWG 26 - 14
- conductors stripping length: 9...11 mm

SQUICH®-spring connection technology

CLOSING

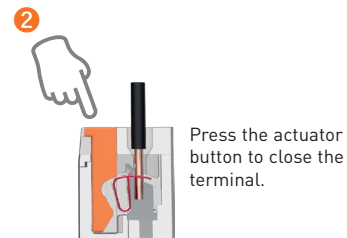
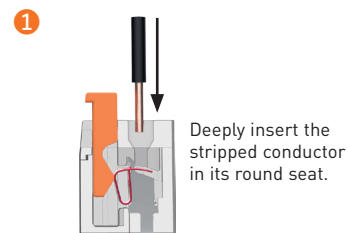

RE-OPENING

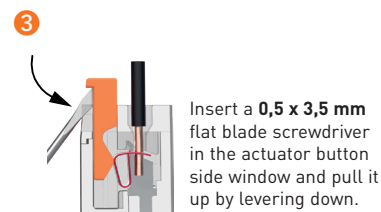

enclosures: size "104.62"	page: 258-266
C-TYPE IP65/IP66	277
C7 IP67, two levers	283-296, 299
V-TYPE IP65/IP66, single lever	316-319
BIG hoods	332-333
T-TYPE IP65 insulating	342-343
T-TYPE / W IP66 insulating	356-357
HYGIENIC T-TYPE / H IP66/IP69	364-365
HYGIENIC T-TYPE / C IP66/IP69, -50 °C	376
W-TYPE for aggressive environments	395
EMC	410-412
Central lever	432-435
IP68	456-457
LS-TYPE	58, 68-69 *
E-Xtreme® corrosion proof	page: 462-463
panel supports: COB	

* refer to NEWS 2017 pages
 ■ refer to CN.16 pages

inserts,
spring terminal connections

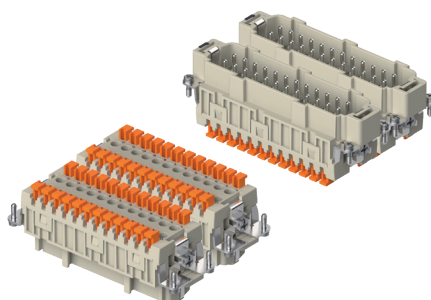

Q STAMPED CONTACTS, SILVER PLATED
 FROM NOVEMBER 2019

description	part No.	part No.
-------------	----------	----------

spring terminals with actuator button
 female inserts with female contacts, No. (1-24) & (25-48)
 male inserts with male contacts, No. (1-24) & (25-48)

CSHF 24 S	CSHF 24 SN
CSHM 24 S	CSHM 24 SN

- characteristics according to EN 61984:
16A 500V 6kV 3
16A 400/690V 6kV 2
- cURus, CSA, CQC, DNV-GL, BV, EAC pending
- rated voltage according to UL/CSA: 600V
- insulation resistance: ≥ 10 GΩ
- ambient temperature limit: -40 °C ... +125 °C
- made of self-extinguishing thermoplastic resin
 UL 94V-0
- mechanical life: ≥ 500 cycles
- contact resistance: ≤ 3 mΩ

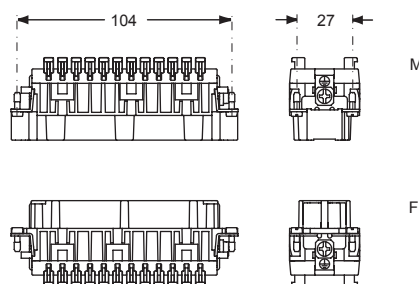

contacts side (front view)

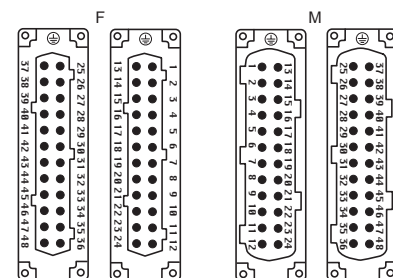

- inserts for connectors with the following conductor cross-sectional areas: 0,14 - 2,5 mm² - AWG 26 - 14
- conductors stripping length: 9...11 mm

SQUICH®-spring connection technology

CLOSING

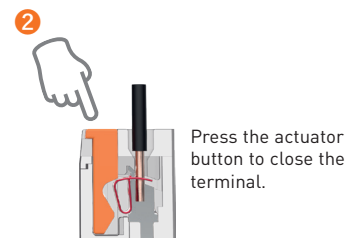
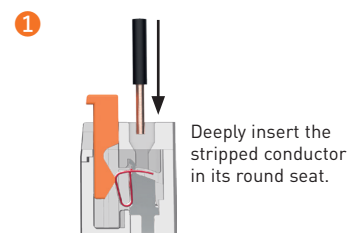

RE-OPENING

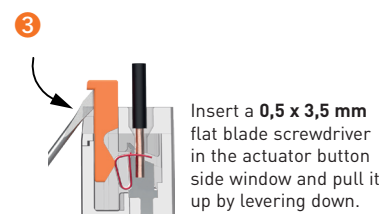

JEI® SQUICH® INSERTS "S" VERSION
(06, 10, 16, 24, 32, 48 poles)

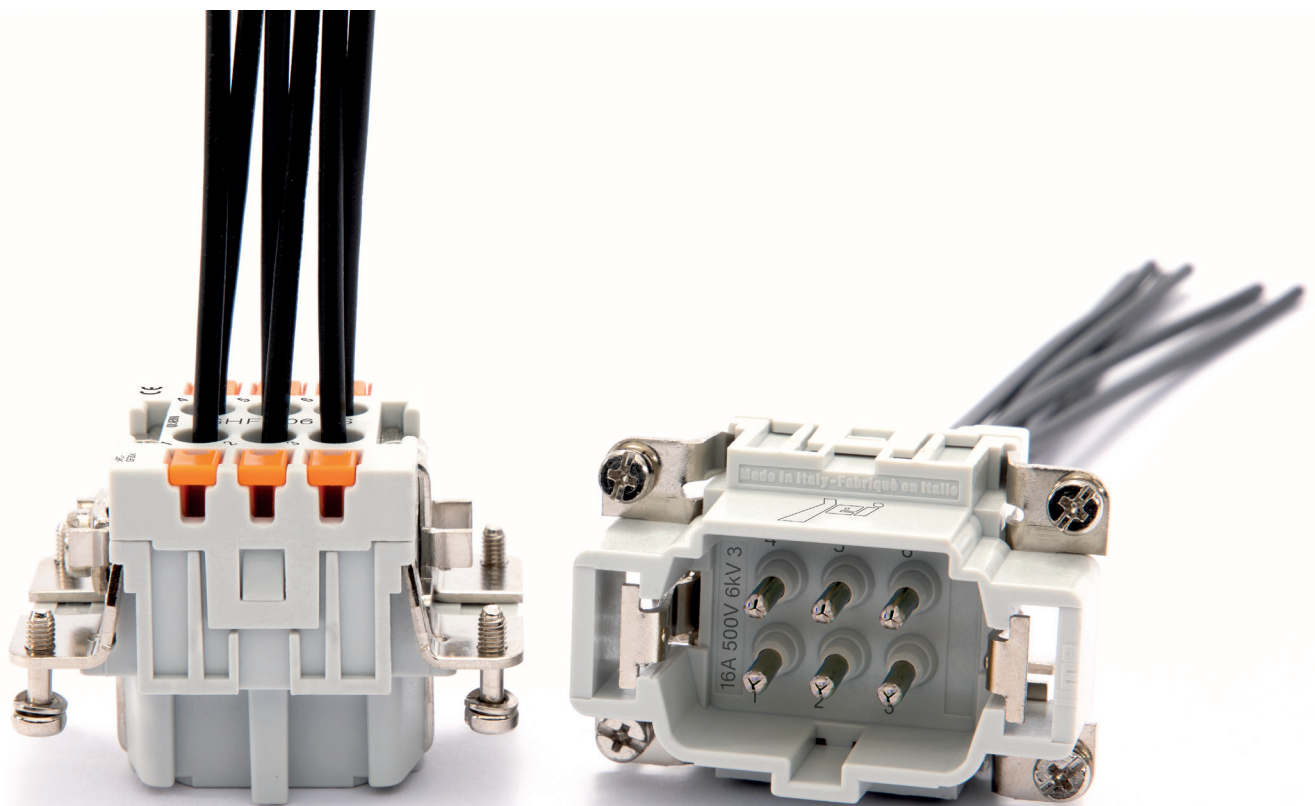

JEI® series inserts
with actuator button,
now with [stamped](#)
[tin-plated contacts](#)



Find more
information on
our products at
www.ilme.com

TECHNICAL FEATURES

JSHF/M 06, 10, 16 (16 SN), 24 (24 SN) S

Demand for cost-effective solutions for large serial production is constantly growing and stamped contacts meet the basic needs for such applications.

Stamped contacts meet the ILME patented SQUICH® technology connector inserts with actuator button, featuring all the well-known advantages of the ILME quick connection technology:

- **JEI® series** variant of the ILME patented CSH-SQUICH® series spring-clamp connector inserts **with actuator button**, featuring a new type of **stamped contacts**;
- **tin plating** of the contacts, suitable for up to **200 mating cycles**:



- provides a **cost-effective choice** for all fields of application neither requiring the extended number of operating cycles nor the superior robustness of solid machined brass contacts of CSH series;

- features all the well-known **advantages of the SQUICH®** proprietary technology:

- **reduced wiring time** (spring-clamp terminals are presented "open", with the actuator button lifted up); up to **50% saving time** compared to screw connection;
- **operator skill independence** (no need to open the spring-clamp terminals by direct operation of a possibly unsuitable tool on the spring);
- **no special wire preparation** (only stripping at the correct length);
- no wiring tool needed;
- **resistance to strong vibrations** typical of the self-compensating spring-clamp technology;
- possibility **to use rigid and flexible** stranded copper conductors with range of cross sectional area between 0,14 mm² and 2,5 mm² (26 - 14 AWG);
- possibility to insert the **test probe** of a measurement instrument in the cavity of the actuator button (proprietary design);
- simple re-opening of a terminal (if needed) using a flat blade screwdriver on the actuator button dedicated side window.

new stamped and tin-plated contacts suitable for up to 200 mating cycles

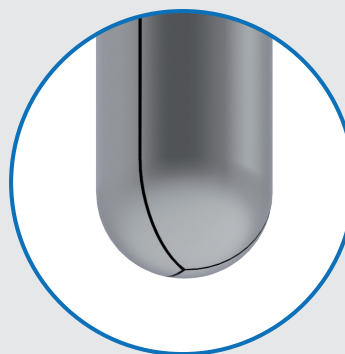
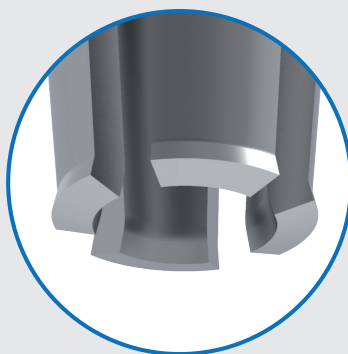

enclosures:
size "44.27" ▶ page:

JEI®-P thermoplastic lever 92 - 93
 JEI®-V zinc-plated steel lever 102 - 104
 T-TYPE IP65 insulating 134 - 135

panel supports: ▶ page:

COB 143 - 144

▶ refer to JEI catalogue

inserts,
spring terminal connections

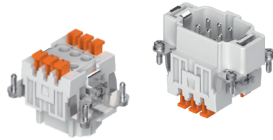

🔍 STAMPED CONTACTS, TIN PLATED
📅 FROM NOVEMBER 2019

description

part No.

spring terminals with actuator button
 female inserts with female contacts
 male inserts with male contacts

JSHF 06 S
 JSHM 06 S

- characteristics according to EN 61984:
16A 500V 6kV 3
16A 400/690V 6kV 2
- cURus, CSA, CQC, DNV-GL, BV, EAC pending
- rated voltage according to UL/CSA: 600V
- insulation resistance: $\geq 10 \text{ G}\Omega$
- ambient temperature limit: $-40 \text{ }^\circ\text{C} \dots +125 \text{ }^\circ\text{C}$
- made of self-extinguishing thermoplastic resin
 UL 94V-0
- mechanical life: ≥ 200 cycles
- contact resistance: $\leq 3 \text{ m}\Omega$

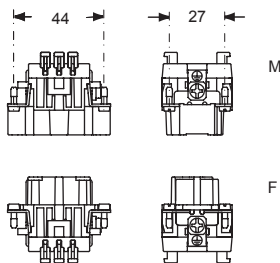

contacts side (front view)

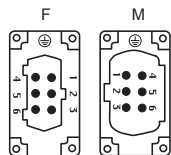

- inserts for connectors with the following conductor cross-sectional areas: $0,14 - 2,5 \text{ mm}^2$ - AWG 26 - 14
- conductors stripping length: 9...11 mm

SQUICH®-spring connection technology

CLOSING

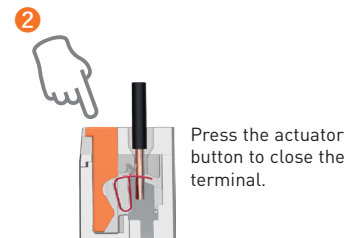
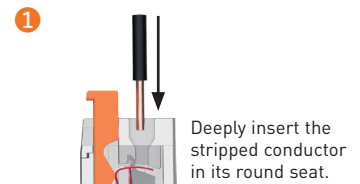

RE-OPENING

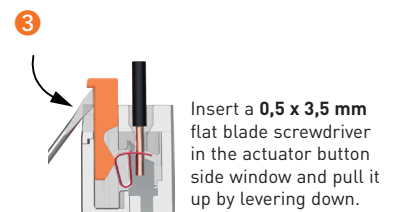

enclosures:
size "57.27"

page:

JEI®-P thermoplastic lever
JEI®-V zinc-plated steel lever
T-TYPE IP65 insulating

94 - 95
105 - 109
136 - 137

panel supports:

page:

COB

143 - 144

refer to JEI catalogue

inserts,
spring terminal connections

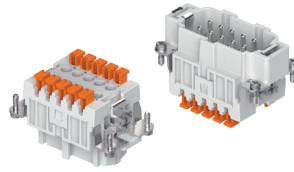

STAMPED CONTACTS, TIN PLATED
FROM NOVEMBER 2019

description

part No.

spring terminals with actuator button
female inserts with female contacts
male inserts with male contacts

JSHF 10 S
JSHM 10 S

- characteristics according to EN 61984:
16A 500V 6kV 3
16A 400/690V 6kV 2
- cURus, CSA, CQC, DNV-GL, BV, EAC pending
- rated voltage according to UL/CSA: 600V
- insulation resistance: $\geq 10 \text{ G}\Omega$
- ambient temperature limit: $-40 \text{ }^\circ\text{C} \dots +125 \text{ }^\circ\text{C}$
- made of self-extinguishing thermoplastic resin
UL 94V-0
- mechanical life: ≥ 200 cycles
- contact resistance: $\leq 3 \text{ m}\Omega$

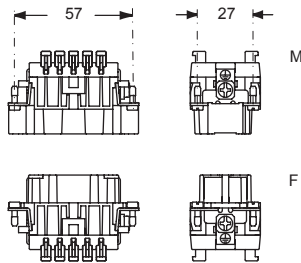

contacts side (front view)

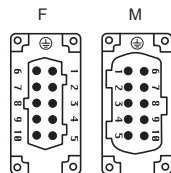

- inserts for connectors with the following conductor cross-sectional areas: $0,14 - 2,5 \text{ mm}^2$ - AWG 26 - 14
- conductors stripping length: 9...11 mm

SQUICH®-spring connection technology

CLOSING

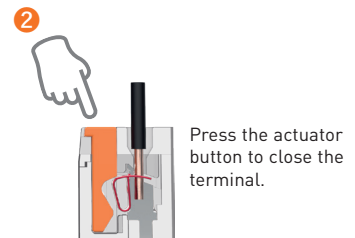
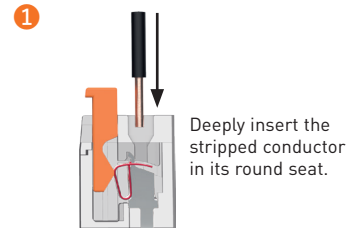

RE-OPENING

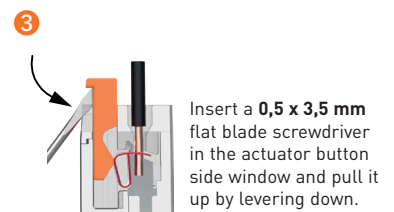

enclosures:
size "77.27" ▶ page:

JEI®-P thermoplastic lever 96 - 97
 JEI®-V zinc-plated steel lever 110 - 114
 T-TYPE IP65 insulating 138 - 139

panel supports: ▶ page:

COB 143 - 144

▶ refer to JEI catalogue

inserts,
spring terminal connections

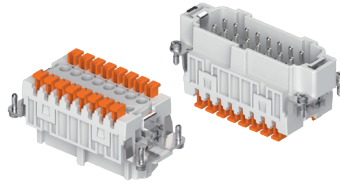

🔍 STAMPED CONTACTS, TIN PLATED
📅 FROM NOVEMBER 2019

description

part No.

spring terminals with actuator button
 female inserts with female contacts
 male inserts with male contacts

JSHF 16 S
 JSHM 16 S

- characteristics according to EN 61984:
16A 500V 6kV 3
16A 400/690V 6kV 2
- cURus, CSA, CQC, DNV-GL, BV, EAC pending
- rated voltage according to UL/CSA: 600V
- insulation resistance: $\geq 10 \text{ G}\Omega$
- ambient temperature limit: $-40 \text{ }^\circ\text{C} \dots +125 \text{ }^\circ\text{C}$
- made of self-extinguishing thermoplastic resin
 UL 94V-0
- mechanical life: ≥ 200 cycles
- contact resistance: $\leq 3 \text{ m}\Omega$

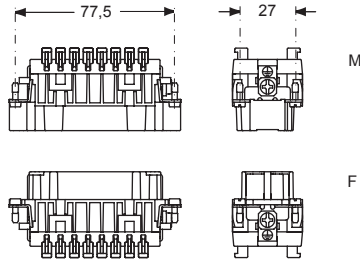

contacts side (front view)

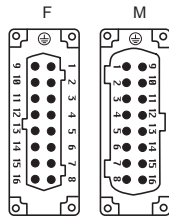

- inserts for connectors with the following conductor cross-sectional areas: $0,14 - 2,5 \text{ mm}^2$ - AWG 26 - 14
- conductors stripping length: 9...11 mm

SQUICH®-spring connection technology

CLOSING

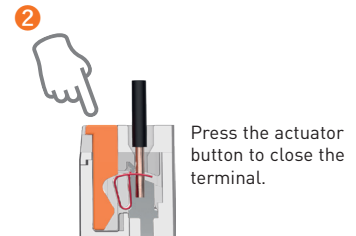
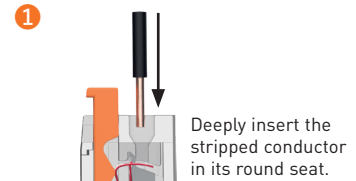

RE-OPENING

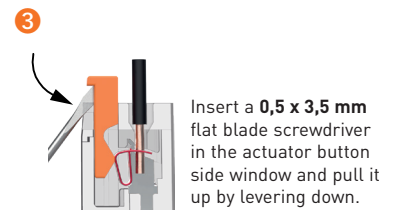

enclosures:
size "104.27"

page:

JEI®-P thermoplastic lever
JEI®-V zinc-plated steel lever
T-TYPE IP65 insulating

98 - 99
115 - 119
140 - 141

panel supports:

page:

COB

143 - 144

refer to JEI catalogue

inserts,
spring terminal connections

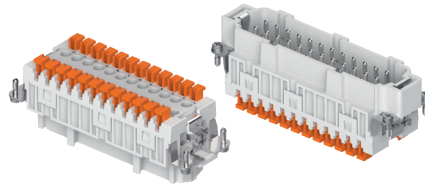

STAMPED CONTACTS, TIN PLATED
FROM NOVEMBER 2019

description

part No.

spring terminals with actuator button
female inserts with female contacts
male inserts with male contacts

JSHF 24 S
JSHM 24 S

- characteristics according to EN 61984:
16A 500V 6kV 3
16A 400/690V 6kV 2
- cURus, CSA, CQC, DNV-GL, BV, EAC pending
- rated voltage according to UL/CSA: 600V
- insulation resistance: $\geq 10 \text{ G}\Omega$
- ambient temperature limit: $-40 \text{ }^\circ\text{C} \dots +125 \text{ }^\circ\text{C}$
- made of self-extinguishing thermoplastic resin
UL 94V-0
- mechanical life: ≥ 200 cycles
- contact resistance: $\leq 3 \text{ m}\Omega$

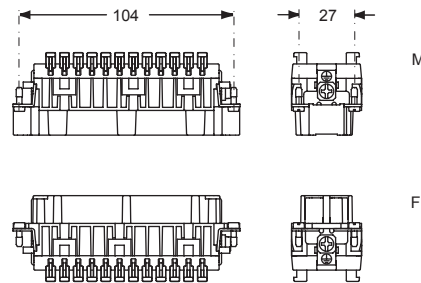

contacts side (front view)

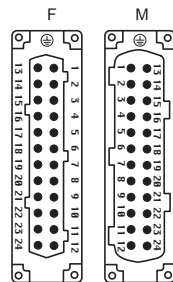

- inserts for connectors with the following conductor cross-sectional areas: $0,14 - 2,5 \text{ mm}^2$ - AWG 26 - 14
- conductors stripping length: 9...11 mm

SQUICH®-spring connection technology

CLOSING

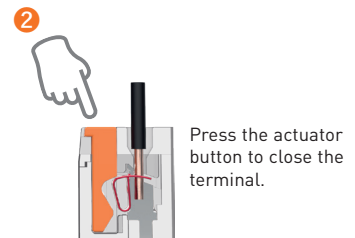
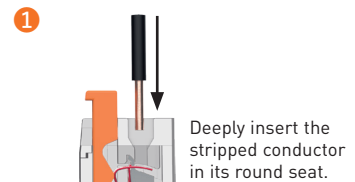

RE-OPENING

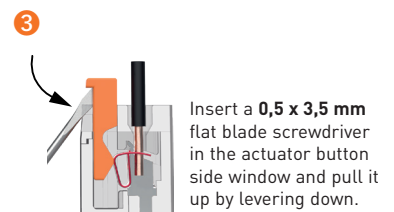

enclosures:
size "77.62"

page:

JEI®-P thermoplastic lever
JEI®-V zinc-plated steel lever

100-101
120-121

inserts,
spring terminal connections

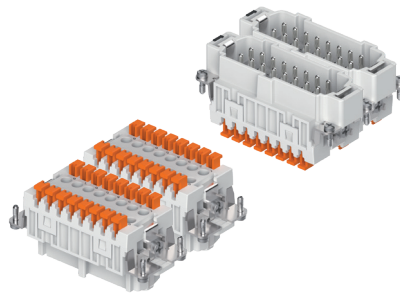

STAMPED CONTACTS, TIN PLATED
FROM NOVEMBER 2019

refer to JEI catalogue

description	part No.	part No.
-------------	----------	----------

spring terminals with actuator button
female inserts with female contacts, No. (1-16) & (17-32)
male inserts with male contacts, No. (1-16) & (17-32)

JSHF 16 S
JSHM 16 S

JSHF 16 SN
JSHM 16 SN

- characteristics according to EN 61984:
16A 500V 6kV 3
16A 400/690V 6kV 2
- cURus, CSA, CQC, DNV-GL, BV, EAC pending
- rated voltage according to UL/CSA: 600V
- insulation resistance: $\geq 10 \text{ G}\Omega$
- ambient temperature limit: $-40 \text{ }^\circ\text{C} \dots +125 \text{ }^\circ\text{C}$
- made of self-extinguishing thermoplastic resin
UL 94V-0
- mechanical life: ≥ 200 cycles
- contact resistance: $\leq 3 \text{ m}\Omega$

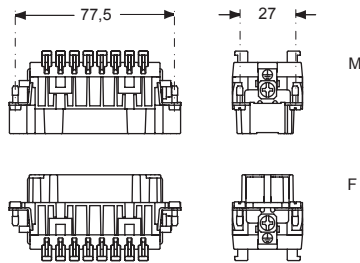

contacts side (front view)

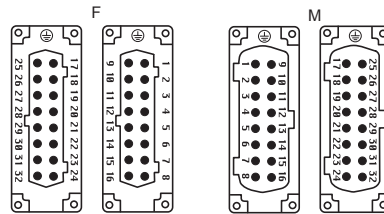

- inserts for connectors with the following conductor cross-sectional areas: $0,14 - 2,5 \text{ mm}^2$ - AWG 26 - 14
- conductors stripping length: 9...11 mm

SQUICH®-spring connection technology

CLOSING

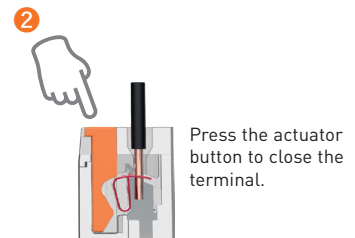
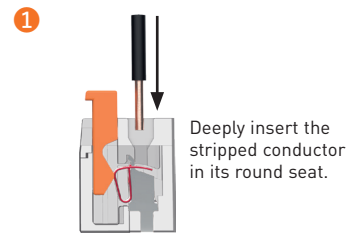

RE-OPENING

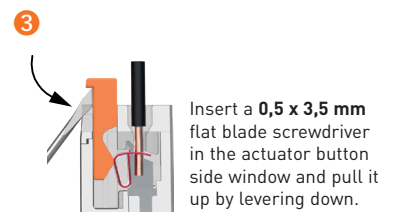

enclosures:
size "104.62"

page:

JEI®-V zinc-plated steel lever

122

inserts,
spring terminal connections

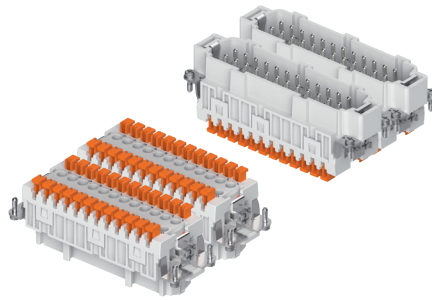

Q STAMPED CONTACTS, TIN PLATED
FROM NOVEMBER 2019

refer to JEI catalogue

description

part No.

part No.

spring terminals with actuator button
female inserts with female contacts, No. (1-24) & (25-48)
male inserts with male contacts, No. (1-24) & (25-48)

JSHF 24 S
JSHM 24 S

JSHF 24 SN
JSHM 24 SN

- characteristics according to EN 61984:
16A 500V 6kV 3
16A 400/690V 6kV 2
- cURus, CSA, CQC, DNV-GL, BV, EAC pending
- rated voltage according to UL/CSA: 600V
- insulation resistance: $\geq 10 \text{ G}\Omega$
- ambient temperature limit: $-40 \text{ }^\circ\text{C} \dots +125 \text{ }^\circ\text{C}$
- made of self-extinguishing thermoplastic resin UL 94V-0
- mechanical life: ≥ 200 cycles
- contact resistance: $\leq 3 \text{ m}\Omega$

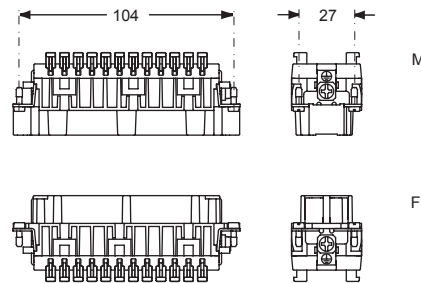

contacts side (front view)

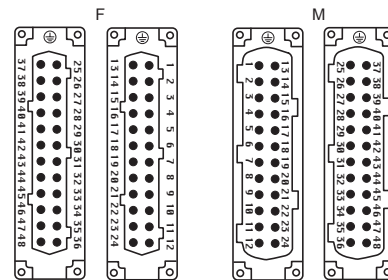

- inserts for connectors with the following conductor cross-sectional areas: $0,14 - 2,5 \text{ mm}^2$ - AWG 26 - 14
- conductors stripping length: 9...11 mm

SQUICH®-spring connection technology

CLOSING

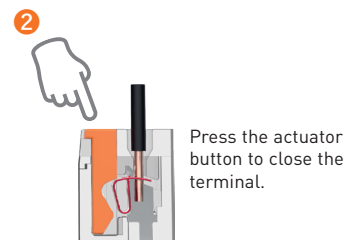
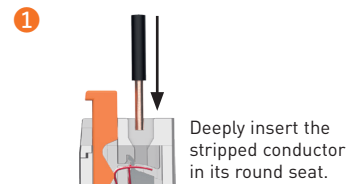

RE-OPENING

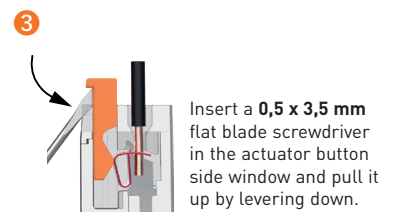

CQ CONNECTOR INSERTS

CQ4F/M 02 - CQ4F/M 02 H

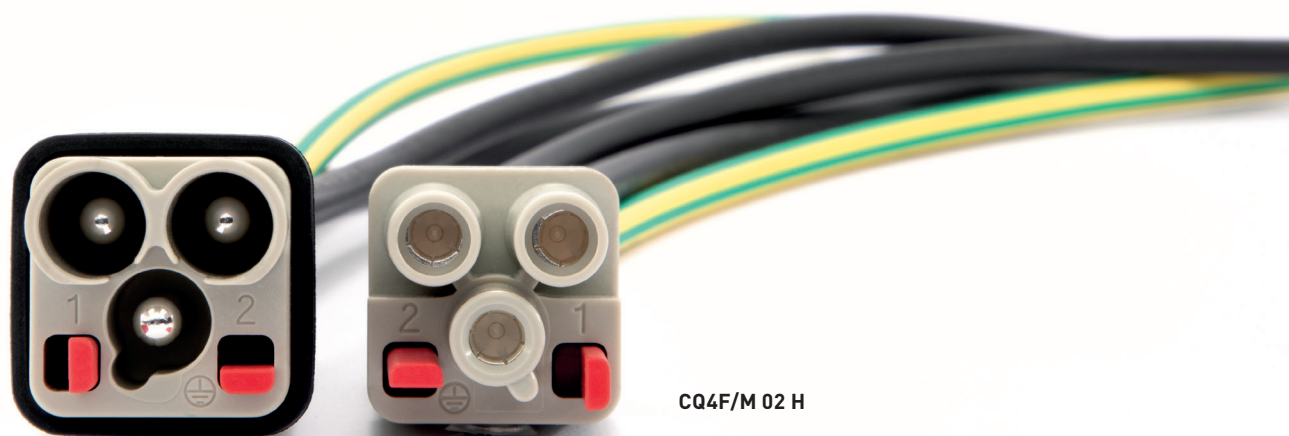

Crimp connector inserts for high current needs,
single phase AC or DC, compact size “21.21”, 2 poles + PE
for CX crimp contacts (including the PE pre-leading one)
fingerproof IP2X, standard version: 40A 400V 6kV 3
higher voltage (H version): 40A 830V 6kV 3

TECHNICAL FEATURES

CQ4F/M 02

- **2P+PE** compact size connector inserts **for high current (40A - 400V 6kV 3); size 21.21**;
- male and female connector inserts **fingerproof IP2X** also on the mating face (useful e.g. when a male connector is on the motor side of a drive, including capacitors, potentially charged for residual time);
- special **polarisation key** on the connector bodies mating face to avoid the mismatching with the higher voltage CQ4F /M 02 H **830V** version;
- suitable for **CX** crimp contacts series (including the PE pre-leading one), covering stranded copper conductors cross sectional area range **1,5 mm² to 10 mm²** (16 AWG to 8 AWG);
- possibility of up to **16 different codings** thanks to the use of **two optional CR Q02 coding pins** (it is possible to install two pins with 4 positions each);
- in combination with high cross-sectional area conductors (large cable diameter), it is advisable to use size "21.21" enclosures with large **M25** threaded cable entry (**MK, MKA, MGK**);
- extends series **CQ4** that now includes the 2P+PE CQ4F/M 02 H higher voltage version and the already available 3P+PE CQ4F/M 03 connector insert.

CQ4F/M 02 H

- **2P+PE** compact size connector inserts **for high current and higher voltage needs (40A - 830V 6kV 3); size "21.21"**;
- male and female connector inserts **fingerproof IP2X** also for the mating face (useful e.g. when a male connector is on the motor side of a drive including capacitors, potentially charged for residual time);
- supplied with a **special insulating heat-shrinking tube** that provides the required additional insulation towards a metal housing;
- special **polarisation key** on the connector bodies mating face to avoid the mismatching with the lower voltage CQ4F/M 02 400V version;
- specific **830V** rated voltage duly marked on the inserts, to avoid any possible confusion with similar CQ4F/M 02 for 400V;
- suitable for **CX** crimp contacts series (including the PE pre-leading one), covering stranded copper conductors cross sectional area range **1,5 mm² to 10 mm²** (16 AWG to 8 AWG);
- possibility of up to **16 different codings** thanks to the use of **two optional CR Q02 coding pins** (it is possible to install two pins with 4 positions each);
- in combination with high cross-sectional area conductors (large cable diameter), it is advisable to use size "21.21" enclosures with large **M25** threaded cable entry (**MK, MKA, MGK**);
- extends series **CQ4** that now includes the 2P+PE CQ4F/M 02 H higher voltage version and the already available 3P+PE CQ4F/M 03 connector insert.

special polarisation key on the connector bodies mating face to avoid the mismatching with the higher 830V voltage version

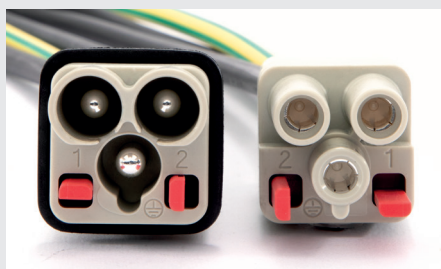

CQ4F/M 02
Lower voltage version

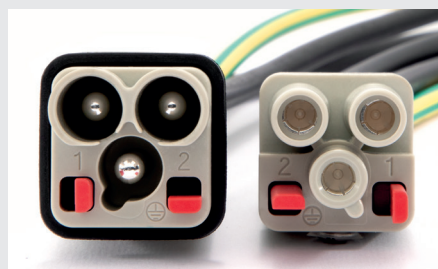

CQ4F/M 02 H
Higher 830V voltage version

CQ4F/M 02 2 poles + ⊕ 40A - 400V

enclosures:
size "21.21"

page:

Insulating type

221 - 222
74 - 77 **

Metallic type

223 - 225
80 - 85 **

W-TYPE for aggressive environments

369

EMC

387

IP68

416 - 418

E-Xtreme® corrosion proof

88 - 89 **
50 - 51 *

- cannot be used in angled enclosures
(IA/IAP/VA version)

* refer to NEWS 2017 pages

** refer to 2019 Multipole connectors pages

refer to CN.16 pages

inserts, crimp connections

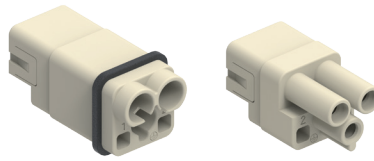

FROM JUNE 2019

40A crimp contacts silver plated



description

part No.

part No.

without contacts (to be ordered separately), including PE
female inserts for female contacts
male inserts for male contacts

CQ4F 02
CQ4M 02

40A female crimp contacts

1,5 mm² AWG 16
2,5 mm² AWG 14
4 mm² AWG 12
6 mm² AWG 10
10 mm² AWG 8

CXFA 1.5
CXFA 2.5
CXFA 4.0
CXFA 6.0
CXFA 10

silver plated

40A male crimp contacts

1,5 mm² AWG 16
2,5 mm² AWG 14
4 mm² AWG 12
6 mm² AWG 10
10 mm² AWG 8

CXMA 1.5
CXMA 2.5
CXMA 4.0
CXMA 6.0
CXMA 10

- characteristics according to EN 61984:

40A 400V 6kV 3

- cURus, CSA, CQC, DNV-GL, BV, EAC pending

- rated voltage according to UL/CSA: 600V

- insulation resistance: ≥ 10 GΩ

- ambient temperature limit: -40 °C ... +125 °C

- made of self-extinguishing thermoplastic resin
UL 94V-0

- mechanical life: ≥ 500 cycles

- contact resistance: ≤ 0,3 mΩ

- **it is recommended to crimp the contacts with crimping tools homologated by ILME** (please see the crimping tool section 40A contacts CXF and CXM series) on pages 531-539 and 544-549 of CN.16 catalogue

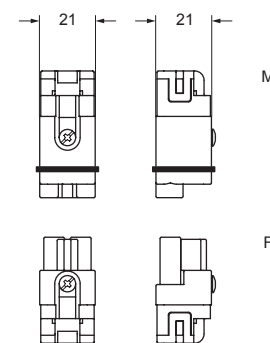

contacts side (front view)



- wire diameter: up to 7,5 mm
conductor cross-sectional area: up to 10 mm²

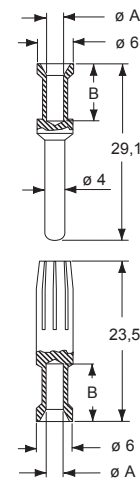

CXF and CXM contacts

conductor cross-sectional area (mm ²)	conductor slot ø A (mm)	conductor stripping length B (mm)
1,5	1,8	9
2,5	2,2	9
4	2,85	9,6
6	3,5	9,6
10	4,3	15

CQ4F/M 02 H 2 poles + ⊕ 40A - 830V

enclosures:
size "21.21"

page:

Insulating type

221 - 222
74 - 77 **

Metallic type

223 - 225
80 - 85 **

W-TYPE for aggressive environments

369

EMC

387

IP68

416 - 418

88 - 89 **

E-Xtreme® corrosion proof

50 - 51 *

- cannot be used in angled enclosures
(IA/IAP/VA version)

* refer to NEWS 2017 pages

** refer to 2019 Multipole connectors pages

refer to CN.16 pages

inserts, crimp connections
heat-shrinking tube

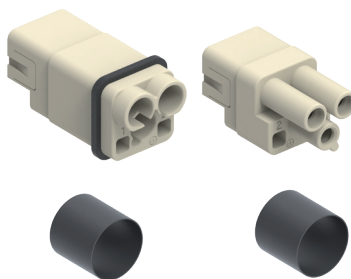

HIGHER VOLTAGE 830V

FROM JUNE 2019

40A crimp contacts
silver plated



description

part No.

part No.

without contacts (to be ordered separately), including PE
female inserts for female contacts
male inserts for male contacts

CQ4F 02 H
CQ4M 02 H

40A female crimp contacts

1,5 mm² AWG 16
2,5 mm² AWG 14
4 mm² AWG 12
6 mm² AWG 10
10 mm² AWG 8

CXFA 1.5
CXFA 2.5
CXFA 4.0
CXFA 6.0
CXFA 10

silver plated

40A male crimp contacts

1,5 mm² AWG 16
2,5 mm² AWG 14
4 mm² AWG 12
6 mm² AWG 10
10 mm² AWG 8

CXMA 1.5
CXMA 2.5
CXMA 4.0
CXMA 6.0
CXMA 10

- characteristics according to EN 61984:

40A 830V 6kV 3

- cURus, CSA, CQC, DNV-GL, BV, EAC pending

- rated voltage according to UL/CSA: 600V

- insulation resistance: ≥ 10 GΩ

- ambient temperature limit: -40 °C ... +125 °C

- made of self-extinguishing thermoplastic resin
UL 94V-0

- mechanical life: ≥ 500 cycles

- contact resistance: ≤ 0,3 mΩ

- **it is recommended to crimp the contacts with**

crimping tools homologated by ILME (please
see the crimping tool section 40A contacts CXF
and CXM series) on pages 531-539 and 544-549 of
CN.16 catalogue

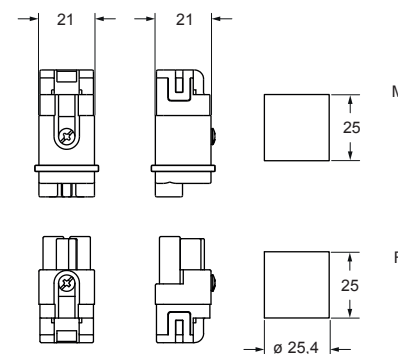

contacts side (front view)



- wire diameter: up to 7,5 mm
conductor cross-sectional area: up to 10 mm²

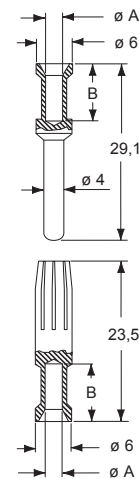

CXF and CXM contacts

conductor cross-sectional area (mm ²)	conductor slot ø A (mm)	conductor stripping length B (mm)
1,5	1,8	9
2,5	2,2	9
4	2,85	9,6
6	3,5	9,6
10	4,3	15

CR Q02 coding pins

coding pins
for crimp inserts



 FROM JUNE 2019

description

part No.

coding pins (optional) for CQ4 02 inserts

CR Q02

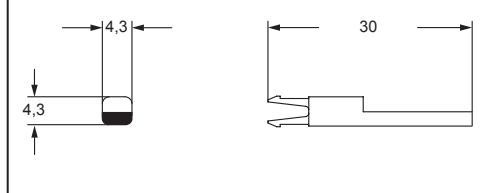

CR Q02 CODING OPTIONS

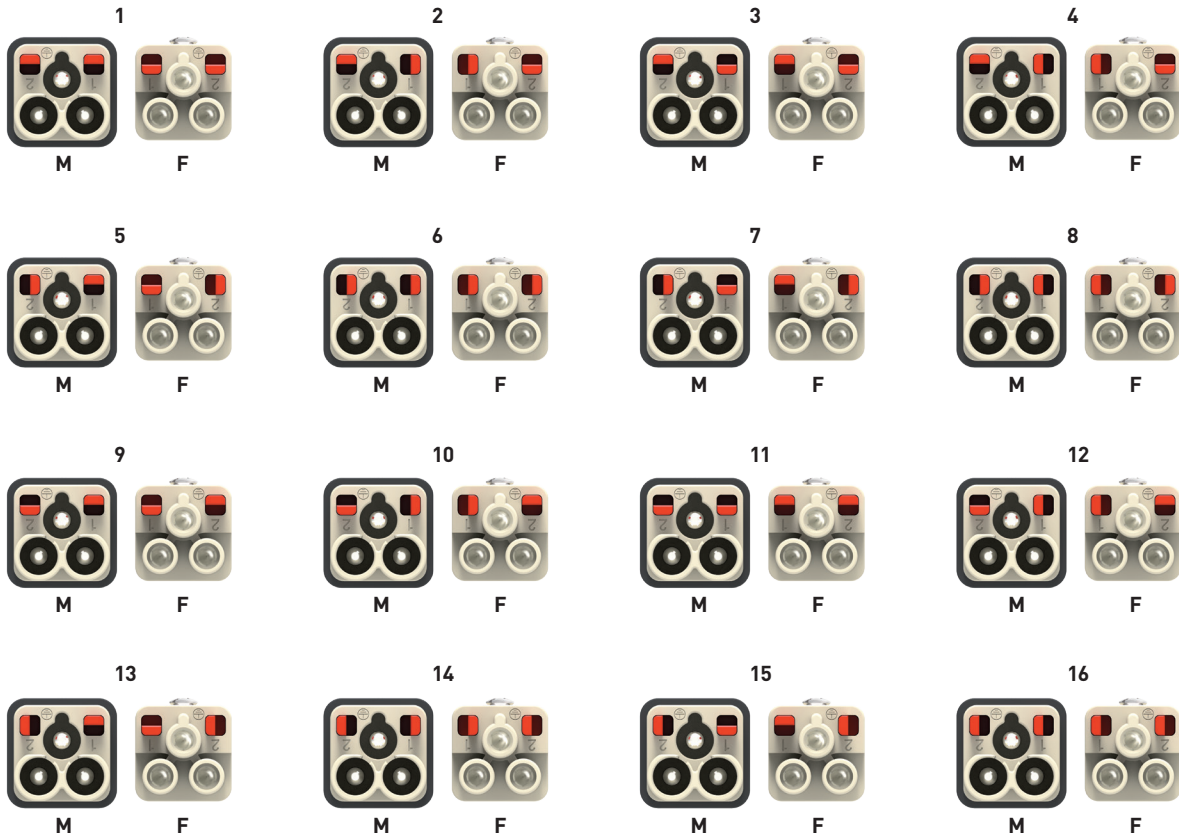

 It is possible to achieve up to **16 different codings** thanks to the use of **two optional CR Q02 coding pins: 4 coding pins for each connector coupling.** It is possible to install two pins with 4 positions each.



CR Q02 coding pins

M= male insert

F = female insert

ASSEMBLY INSTRUCTIONS

CQ4F/M 02 H

1

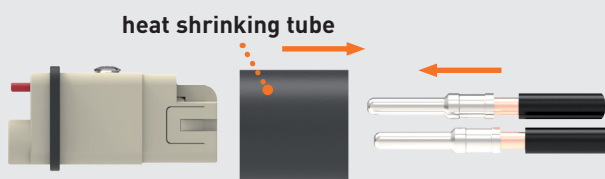

2

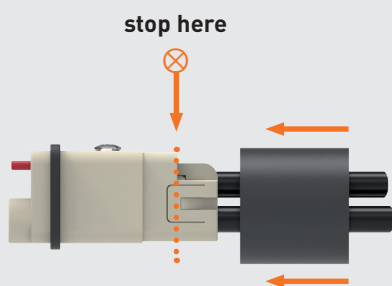

3



4

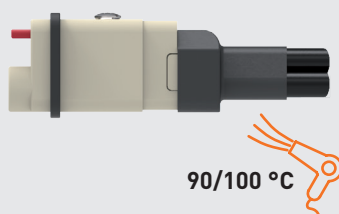

HIGH NUMBER OF MATINGS

RXF/M 12/2 CRIMP CONNECTOR INSERTS

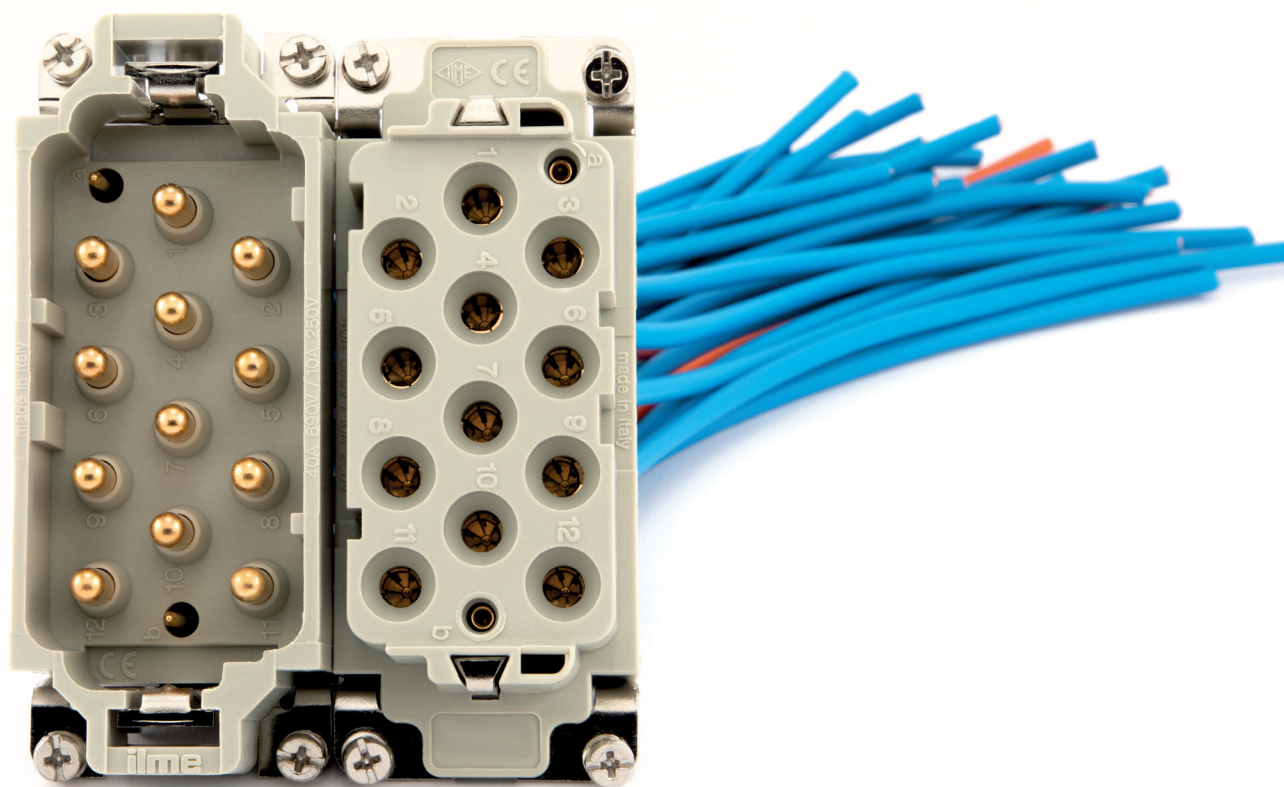

12 poles (power) connector
40A - 690V for RX series HNM crimp contacts,
+ 2 poles (auxiliary)
10A - 250V for RD series HNM crimp contacts + PE



Find more
information on
our products at
www.ilme.com

TECHNICAL FEATURES

RXF/M 12/2

- special **HNM** version (**High Number of Matings** up to 10.000 cycles) of CXF/M 12/2 connector inserts, to be used in combination with:
 - **up to 12 40A HNM gold plated removable crimp contacts** of the **new RX** series,
 - **2 10A HNM gold plated removable crimp contacts** of the **already available RD** series;
- crimp connector inserts with a combination of 12 power contacts (40A) plus 2 auxiliary contacts (10A) + PE;
- suitable for the operation of 4 three-phase AC motors with 2 auxiliary contacts;
- **10.000 matings** with HNM enclosures;
5.000 matings with standard enclosures, single lever.

featuring a special
antifriction treatment to
guarantee up to 10.000
mating cycles

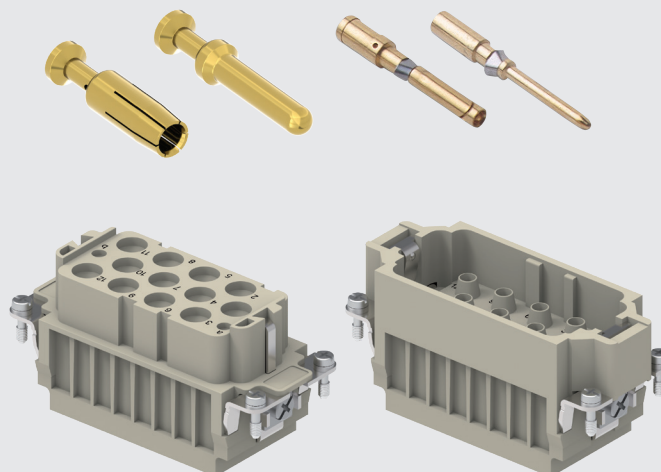

enclosures:
size "77.27"

page:

HNM
C-TYPE IP65/IP66, single lever
V-TYPE IP65/IP66, single lever

94-95 *
250-256
282-292, 295

inserts, crimp connections

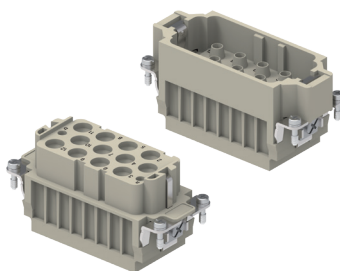

FROM MARCH 2019

40A and 10A crimp contacts
gold plated



40A: FROM MARCH 2019

* refer to NEWS 2017 pages
refer to CN.16 pages

description	part No.	part No
-------------	----------	---------

without contacts (to be ordered separately)
female inserts for female contacts
male inserts for male contacts

RXF 12/2
RXM 12/2

40A female crimp contacts
1,5 mm² AWG 16
2,5 mm² AWG 14
4 mm² AWG 12
6 mm² AWG 10

RXF2D 1.5
RXF2D 2.5
RXF2D 4.0
RXF2D 6.0

gold plated

40A male crimp contacts
1,5 mm² AWG 16
2,5 mm² AWG 14
4 mm² AWG 12
6 mm² AWG 10

RXM2D 1.5
RXM2D 2.5
RXM2D 4.0
RXM2D 6.0

10A female contacts

0,14-0,37 mm ²	AWG 26-22	identification No. 1
0,5 mm ²	AWG 20	identification No. 2
0,75 mm ²	AWG 18	identification No. ②
1 mm ²	AWG 18	identification No. 3
1,5 mm ²	AWG 16	identification No. 4
2,5 mm ²	AWG 14	identification No. 5

RDF2D 0.3
RDF2D 0.5
RDF2D 0.7
RDF2D 1.0
RDF2D 1.5
RDF2D 2.5

gold plated

10A male contacts

0,14-0,37 mm ²	AWG 26-22	identification No. 1
0,5 mm ²	AWG 20	identification No. 2
0,75 mm ²	AWG 18	identification No. ②
1 mm ²	AWG 18	identification No. 3
1,5 mm ²	AWG 16	identification No. 4
2,5 mm ²	AWG 14	identification No. 5

RDM2D 0.3
RDM2D 0.5
RDM2D 0.7
RDM2D 1.0
RDM2D 1.5
RDM2D 2.5

- characteristics according to EN 61984:

40A 690V 8kV 3
10A 250V 4kV 2

- cURus, CSA, CQC, DNV-GL, BV, EAC pending
- rated voltage according to UL/CSA: 600V
- insulation resistance: ≥ 10 GΩ
- ambient temperature limit: -40 °C ... +125 °C
- made of self-extinguishing thermoplastic resin UL 94V-0
- mechanical life: ≥ 10.000 cycles
- contact resistance: ≤ 0,3 mΩ (12 poles), ≤ 1 mΩ (2 poles)
- for maximum current load refer to the following connector inserts derating diagram

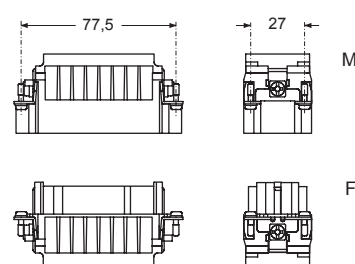

contacts side (front view)

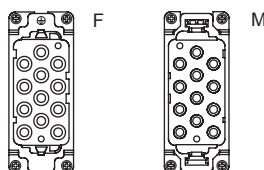

RX 12/2 power poles connector inserts
Maximum current load derating diagram

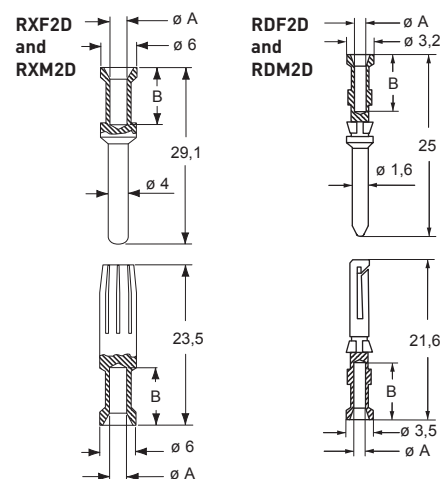
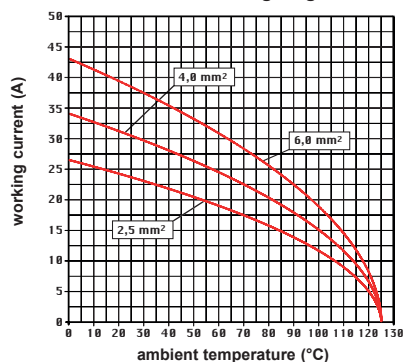

RXF2D and RXM2D contacts

conductor cross-sectional area mm ²	conductor slot ø A (mm)	conductor stripping length B (mm)
1,5	1,8	9
2,5	2,2	9
4	2,85	9,6
6	3,5	9,6

RDF2D and RDM2D contacts

conductor cross-sectional area mm ²	conductor slot ø A (mm)	conductor stripping length B (mm)
0,14-0,37	0,9	8
0,5	1,1	8
0,75	1,3	8
1,0	1,45	8
1,5	1,8	8
2,5	2,2	6

- it is recommended to crimp the contacts with crimping tools homologated by ILME (please see the crimping tool section 40A contacts, RXF2D, RXM2D series and 10A contacts RDF2D, RDM2D series) on pages 531-539 and 544-549 of CN.16 catalogue



MIXO SERIES

The MIXO series, featuring a flexible modular design for an easy and safe installation, is continuously expanded with new modules allowing more possibilities and performance to built connectors more and more customized:

- **CX 05 SHF/M, MIXO 16A**
SQUICH® module with spring clamp contacts actuator buttons
 single-sized, 5 poles, 16A – 400V
- **CX 42 DF/DM, MIXO 10A**
crimp module, double-sized, 42 poles,
 10A – 150V

Besides the new modules, MIXO series widens its portofolio with the following novelties:

- **MIXO ONE series of housings for the single sized modules**,
 see page 52
- **CR 16 SSD / 24 SSD anchorages for off-axis fastening**,
 see page 116
- **CGT 6.0, CGT 10 and CGT PE adapters for MIXO frames**
 in addition to the existing CGT 16, see page 120

MIXO SERIES AT A GLANCE

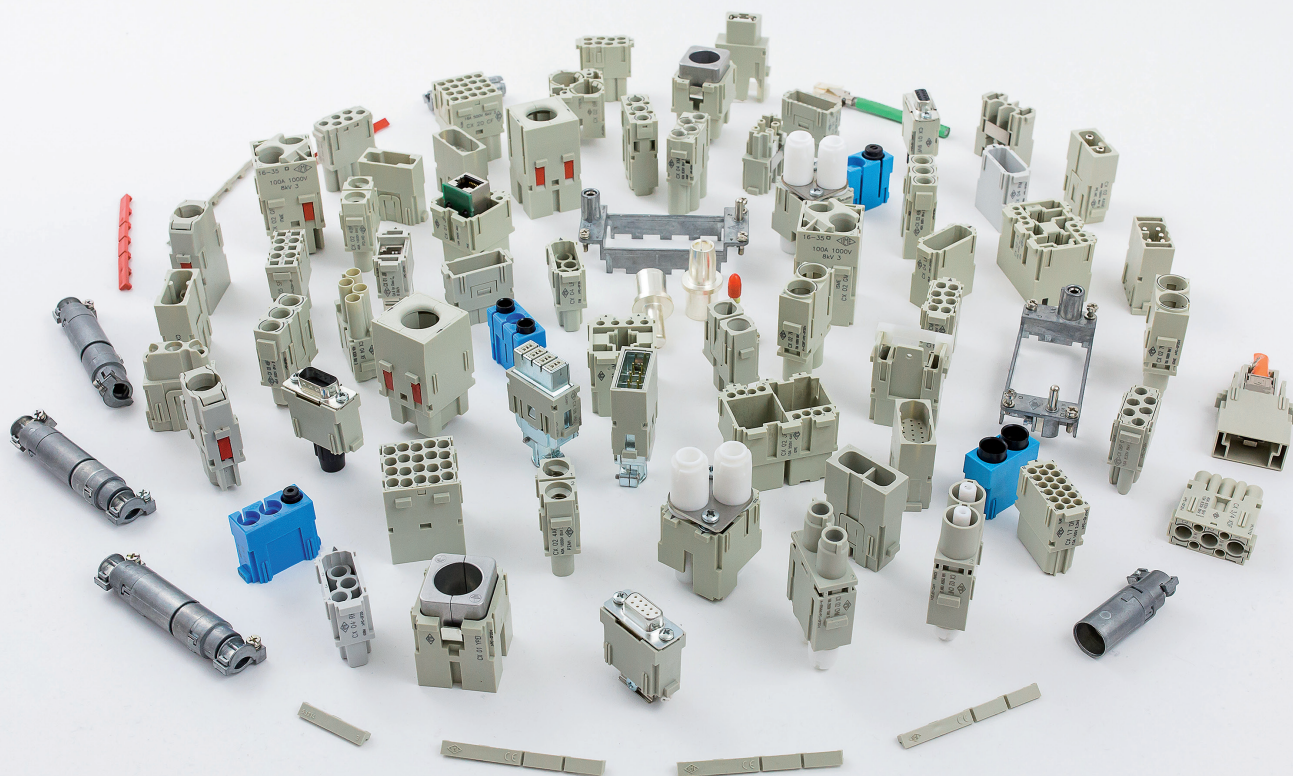

THE COMPLETE RANGE OF MODULES

2019 products are marked with the **+** symbol.

Inserts	Contact type	Signal type	Kind of connection	Rated current (A)	Rated voltage (V)	No. of frame slots	HNM suitable
CX 01 YF/M	main	electric	crimp	200	1000	2	—
CX 01 YPEF/M	PE	—	crimp	200	—	2	—
CX 01 GF/M	main	electric	crimp	100	830	1	—
CX 02 GF/M	main	electric	crimp	100	1000	2	—
CX 02 7F/M	main	electric	crimp	70	1000	1	—
CX 02 4AF/M	main	electric	axial screw	40	1000	1	—
CX 02 4BF/M	main	electric	axial screw	40	1000	1	—
CX 02 4F/M	main	electric	crimp	40	1000	1	—
CX 03 4F/M	main	electric	crimp	40	400/690	1	yes
CX 03 4BF/BM	main	electric	crimp	40	500	1	yes
CX 3/4 XDF/M	main	electric	crimp	40/10	830	1	—
CX 04 XF/M	main	electric	crimp	40	830	1	yes
CX 05 SF/M	main	electric	spring	16	400	1	—
+ CX 05 SHF/M	main	electric	SQUICH®-spring	16	400	1	—
CX 06 CF/M	main	electric	crimp	16	500	1	yes
CX 06P CF/M	main	electric	crimp	16	830	1	yes
CX 08 CF/M	main	electric	crimp	16	400	1	yes
CX 08 I6F/M	main	electric	crimp	5	50	1	—
CX 20 CF/M	main	electric	crimp	16	500	2	yes
CX 12 DF/M	main / auxiliary	electric	crimp	10	250	1	yes
CX 17 DF/M	main / auxiliary	electric	crimp	10	160	1	yes
+ CX 42 DF/M	main / auxiliary	electric	crimp	10	150	2	yes
CX 25 IBF/M	main / auxiliary	electric	crimp	4	50	1	—
CX 25 IF/M	main / auxiliary	electric	crimp	4	50	1	—
CX 02 CHF/M	main	electric	crimp	16	2500	1	—
CX 02 HF/M	main	electric	crimp	16	2900/5000	2	—
CX 02 BF/M	seat for two shielded connectors (refer to CX 04 B, CX 01 B, CX 01 BC, CX 08 B)					2	—
CX 01 BCF/M	main / auxiliary + shield	electric	crimp	16	50	—	—
CX 01 BF/M	main / auxiliary + shield	electric	crimp	10	50	—	—
CX 04 BF/M	main / auxiliary + shield	electric	crimp	10	50	—	—
CX 08 BF/M	main / auxiliary + shield	electric	crimp	5	50	—	—
CX 03 P	pneumatic Ø 1,6 - 3,0 - 4,0 mm	air	push-in	—	—	1	—
CX 02 P	pneumatic Ø 6,0 mm	air	push-in	—	—	1	—
CX FM	none (dummy module)	—	—	—	—	1	yes
CX 01 J8F/M/IM	RJ45	electric	crimp/IDC	—	—	1	—
CX 01 JF/M	RJ45 + auxiliary	electric	crimp	10	250	2	—
CX 02 JF/M	RJ45 + auxiliary	electric	crimp	10	250	3	—
CX 01 UF/M	USB	electric	—	—	—	1	—
CX 01 9VF/M	D-SUB	electric	crimp	5	50	1	—
CX 01 9VTF	D-SUB	electric	screw	5	50	1	—
CX 04 LF/M	POF / MOST	optic	crimp	—	—	1	—
CX 04 RF/M	coaxial	electric	crimp	—	—	1	—
CX 04 SCF/M	SC fibre optic	optic	crimp/glue	—	—	1	—

Calculate the number of frame slots taken up by the required inserts (frame slot 1, 2 or 3 modules) and select the right frame according to the number of required modules (available 1, 2, 3, 4 and 6 modules). For more information refer to pages 45, 49.



size: 1 frame slot

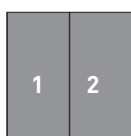

size: 2 frame slots



size: 3 frame slots

MIXO - SQUICH®
CX 05 SHF/SHM

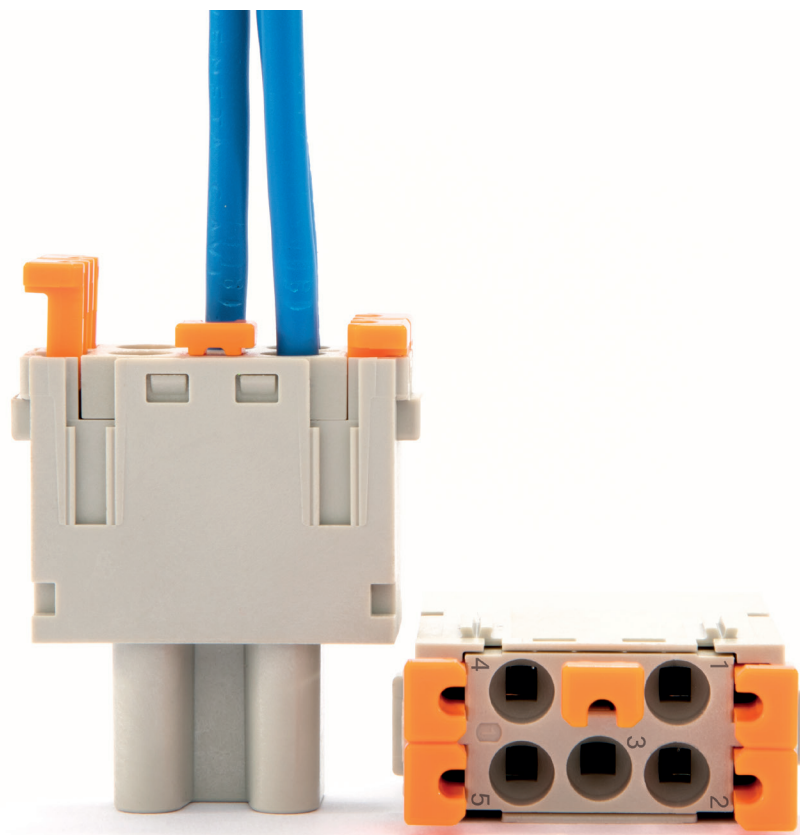

MIXO 5 poles,
SQUICH® version
spring with actuator buttons
16A 400V 6kV 3



Watch
our
SQUICH®
video

TECHNICAL FEATURES

CX 05 SHF/SHM

- **SQUICH®** technology has now been applied to the ILME MIXO series of modular connectors. Main aim is to make wiring an installation easier and safer on every possible connector. On this purpose, the new MIXO SQUICH® 5 poles is the improved version of the CX 05 SF/SM spring clamp module;
- **consistently reduced wiring time**, as the actuator buttons are supplied lifted, in “open terminal” position, so that the stripped wires can be directly inserted;
- **operator skill independence**: thanks to the SQUICH® proprietary technology a simple pressure on the top of the actuator button triggers the locking of the conductor in the terminal, avoiding the need of a specific screwdriver and the relevant skill in its correct choice and application;
- **great resistance to strong vibrations** inherent to self-compensating spring-clamp technology;
- **no special wire preparation** (only stripping at the correct length);
- it allows the **use of both rigid and flexible** copper conductors, with a range of cross-sectional area between 0,14 mm² and 2,5 mm² (26 AWG to 14 AWG);
- for conductors prepared with **crimped ferrules**, the maximum cross-sectional area is 1,5 mm²;
- possibility to insert the **test probe** of a measurement instrument in the dedicated cavity on the actuator button (proprietary design);
- **silver plated** contacts;
- simple re-opening of a terminal (if needed) using a 0,5 x 3 mm flat blade screwdriver on the actuator button dedicated side window (on terminal #3 use the same screwdriver under any of the two lateral projections of the actuator button head; after removing the wire from the relevant terminal #1 or #4).

features
new patented
actuator buttons
in a compact
version

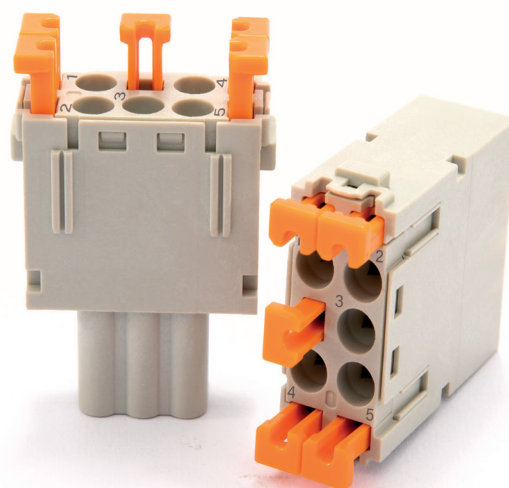

CX 05 SHF/SHM 5 poles 16A - 400V SQUICH®

The modular inserts must be installed in suitable frames which are then mounted in traditional housings or COB panel support.

frames for modular units	pages: 45, 49
enclosures: MIXO ONE	52

modular units,
SQUICH®-spring terminal connection

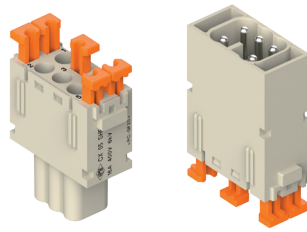

FROM JULY 2019

description	part No.
-------------	----------

spring terminals with actuator button
female inserts with female contacts
male inserts with male contacts

CX 05 SHF
CX 05 SHM

- characteristics according to EN 61984:
16A 400V 6kV 3
16A 500V 6kV 2
- cURus, CSA, CQC, DNV-GL, BV, EAC pending
- rated voltage according to UL/CSA: 600V
- insulation resistance: $\geq 10 \text{ G}\Omega$
- ambient temperature limit: $-40 \text{ }^\circ\text{C} \dots +125 \text{ }^\circ\text{C}$
- made of self-extinguishing thermoplastic resin UL 94V-0
- mechanical life: ≥ 500 cycles
- contact resistance: $\leq 3 \text{ m}\Omega$
- for maximum current load refer to the connector inserts derating diagram here below

Suitable for every conductor type (prepared with ferrule, unprepared and solid) up to cross-sectional area $2,5 \text{ mm}^2$

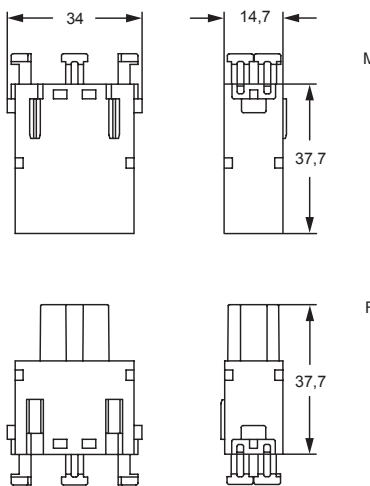

contacts side (front view)

rear view, side with reference arrow ▲

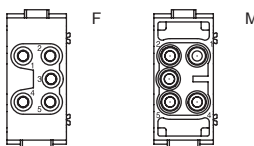

- 1 frame slot

- inserts for cables with the following cross-sectional area: $0,14 - 2,5 \text{ mm}^2$ - AWG 26 - 14
- conductors stripping length: $9 \dots 11 \text{ mm}$

CX 05 SHF/SHM power poles connector inserts
Maximum current load derating diagram

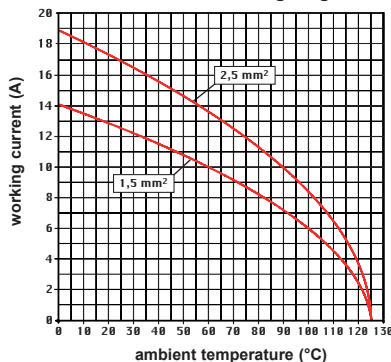

MIXO CX 05 SHF/M
SQUICH®-spring connection technology

CLOSING

- Deeply insert the stripped conductor in its round seat.
- Press the actuator button to close the terminal.

RE-OPENING

- SIDE (#1 - #2 - #4 - #5)**
Insert a $0,5 \times 3 \text{ mm}$ flat blade screwdriver in the actuator button side window and pull it up by levering down.
- CENTRE (#3)**
Free and re-close (per 3 above) terminal #1 or #4.
- Insert the screwdriver under the projection of actuator button head #3 and pull it up by levering down.

CX 01 T

enclosures: size "49.16"	page:	frames for modular units
IL-BRID	230 - 232	
W-TYPE	370	
EMC	390	
panel supports: COB + adapter	462 - 464	

refer to CN.16 pages

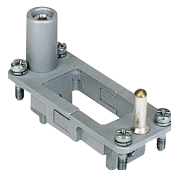

description	part No.
-------------	----------

for CZ enclosures

CX 01 T

- die-cast zinc alloy frame
- pre-leading protective earth (PE)
- coding pins CR..CX

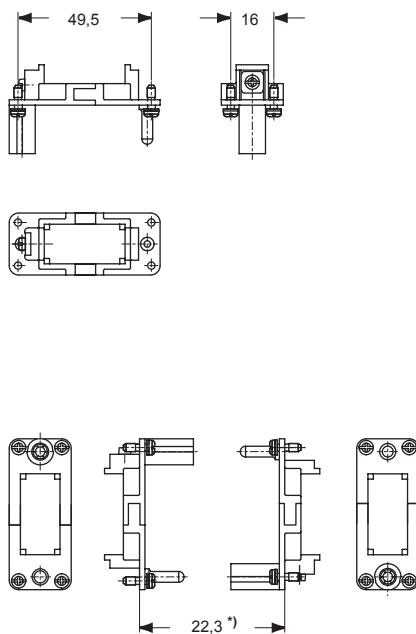

*) distance for electric contacts: max 24 mm
distance for pneumatic contacts: max 23,5 mm

- small protective earth terminal for conductors with cross-sectional area range 1-2,5 mm², AWG 18-14

MIXO
CX 42 DF/DM

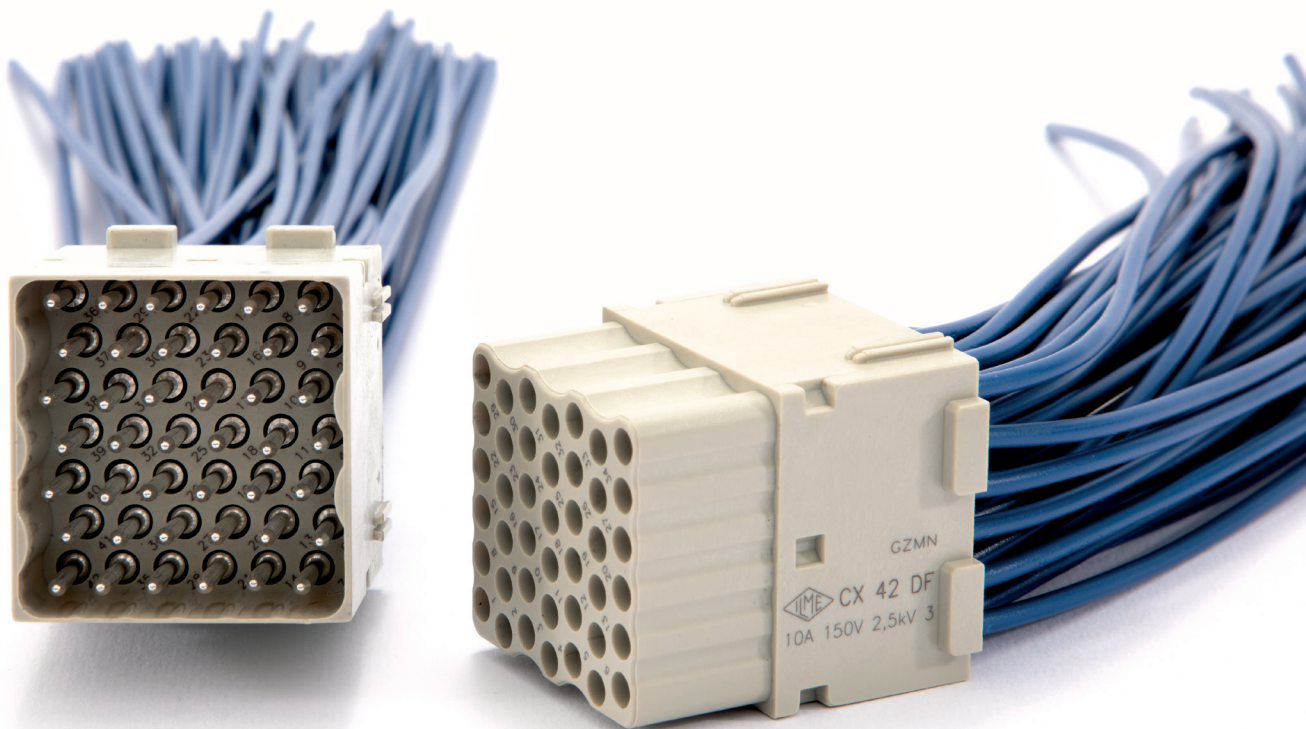

MIXO 42 poles (crimp),
for use with max 10A CD series,
10A 150V 2,5kV 3



Find more
information on
our products at
www.ilme.com

TECHNICAL FEATURES

MIXO CX 42 DF/DM

- double-sized module, **for max 10A removable crimp contacts of CD series;**
- high contacts density allowing **to accommodate up to 42 contacts**, while using the same space of two CX 17 DF/DM modules and relevant 34 contacts (suitable to obtain e.g. a 126-pole with a 6-slot MIXO frame);
- suitable for realizing **HNM** connectors (High Number of Matings up to 10.000 cycles) when used in combination with: HNM MIXO frames, HNM crimp contacts RD series and HNM enclosures;
- supplied with dedicated black coloured 2-slot sized lock-in tabs (2, one per each side).

42 contacts.
Contacts density
raised by 20%
(compared
to previous
solution)



CX 42 DF/DM 42 poles 10A - 150V

The modular inserts must be installed in suitable frames which are then mounted in traditional housings * or COB panel support.

frames for modular units * pages: 49

* enclosures: bulkhead mounting housings, high construction housings or high construction hoods

modular units, crimp connections

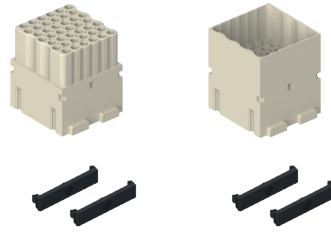

FROM MAY 2019

10A crimp contacts, silver and gold plated



description

part No.

part No

without contacts (to be ordered separately), supplied with 2 dedicated black coloured 2-slot sized lock-in tab female inserts for female contacts male inserts for male contacts

CX 42 DF
CX 42 DM

10A female crimp contacts

0,14-0,37 mm ²	AWG 26-22	identification No. 1
0,5 mm ²	AWG 20	identification No. 2
0,75 mm ²	AWG 18	identification No. ②
1 mm ²	AWG 18	identification No. 3
1,5 mm ²	AWG 16	identification No. 4
2,5 mm ²	AWG 14	identification No. 5

10A male crimp contacts

0,14-0,37 mm ²	AWG 26-22	identification No. 1
0,5 mm ²	AWG 20	identification No. 2
0,75 mm ²	AWG 18	identification No. ②
1 mm ²	AWG 18	identification No. 3
1,5 mm ²	AWG 16	identification No. 4
2,5 mm ²	AWG 14	identification No. 5

CDFA 0.3	silver plated	CDFD 0.3	gold plated ⁺
CDFA 0.5		CDFD 0.5	
CDFA 0.7		CDFD 0.7	
CDFA 1.0		CDFD 1.0	
CDFA 1.5		CDFD 1.5	
CDFA 2.5		CDFD 2.5	
CDMA 0.3		CDMD 0.3	
CDMA 0.5		CDMD 0.5	
CDMA 0.7		CDMD 0.7	
CDMA 1.0		CDMD 1.0	
CDMA 1.5		CDMD 1.5	
CDMA 2.5		CDMD 2.5	

- characteristics according to EN 61984:
- 10A 150V 2,5kV 3**
- cURus, CSA, CQC, DNV-GL, BV, EAC pending
- rated voltage according to UL/CSA: 250V
- insulation resistance: ≥ 10 GΩ
- ambient temperature limit: -40 °C ... +125 °C
- made of self-extinguishing thermoplastic resin UL 94V-0
- mechanical life: ≥ 10.000 cycles
- contact resistance: ≤ 3 mΩ
- **it is recommended to crimp the contacts with crimping tools homologated by ILME** (please see the crimping tool section 10A contacts, CDF and CDM series) on pages 531-539 and 544-549 of CN.16 catalogue
- supplied with dedicated black coloured 2-slot sized lock-in tab (2, one per each side)
- for spare lock-in tab **CX CFMD** see SPARE SPARTS catalogue

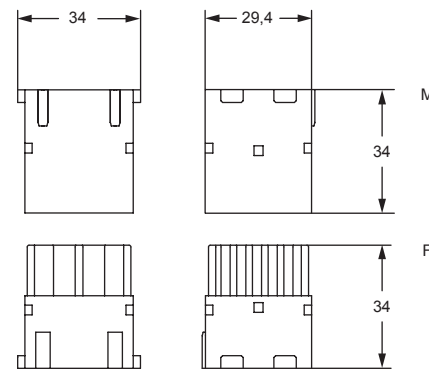

contacts side (front view)

rear view, side with reference arrow ▲

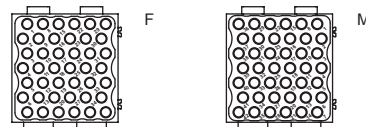

- 2 frame slots

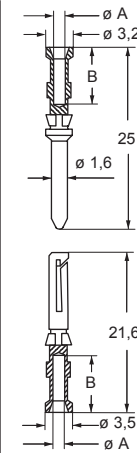

CDF and CDM contacts

conductor section (mm ²)	conductor slot ø A (mm)	conductors stripping length B (mm)
0,14-0,37	0,9	8
0,5	1,1	8
0,75	1,3	8
1,0	1,45	8
1,5	1,8	8
2,5	2,2	6

⁺ for basic or high thickness gold plating, please refer to page 480 of CN 16 catalogue

CX 02 TM/TF, CX 03 TM/TF, CX 04 TM/TF, CX 06 TM/TF

enclosures:

	page:
T-TYPE IP65/IP66	240 - 271
C7 IP67	274 - 277
V-TYPE IP65/IP66	280 - 299
BIG	304 - 319
T-TYPE IP65	326 - 333
T-TYPE/ W IP66	336 - 343
HYGIENIC T-TYPE/H	350 - 357
HYGIENIC T-TYPE/C	358 - 365
W-TYPE	373 - 378
E-Xtreme® corrosion proof	42-49, 55-60, 62-69 *
EMC	392 - 395
CENTRAL LEVER	404 - 412
IP68	420 - 435
LS-TYPE	450 - 457

panel supports:

COB + adapter	462 - 463
---------------	-----------

* refer to NEWS 2017 pages

refer to CN.16 pages

frames for modular units with lock-in tab (included)

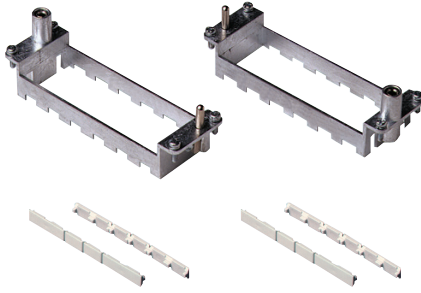

description

part No.

frames for modular units with lock-in tab included

- for 2 modular units - for housing size 44.27
- for 3 modular units - for housing size 57.27
- for 4 modular units - for housing size 77.27 and 77.62
- for 6 modular units - for housing size 104.27 and 104.62

type for hoods

- CX 02 TM
- CX 03 TM
- CX 04 TM
- CX 06 TM

type for housings

- CX 02 TF
- CX 03 TF
- CX 04 TF
- CX 06 TF

- die-cast zinc alloy frames
- protective earth (PE)
- possibility of mounting female and male modular units on the same frame
- frames supplied with lock-in tab to attach units
- polarisation on frames
- coding pins **CR..CX**
- for spare lock-in tab **CX CFM** see SPARE SPARTS catalogue

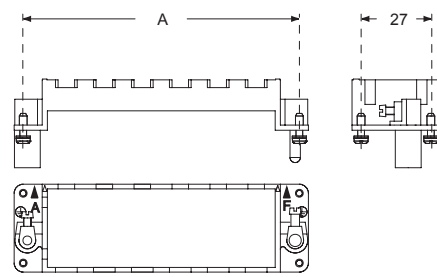

part No.	A (mm)	for housings size
CX 02 TM / TF	44	44,27
CX 03 TM / TF	57	57,27
CX 04 TM / TF	77,5	77,27 and 77,62
CX 06 TM / TF	104	104,27 and 104,62

Earth terminal

- large: for cables from 4-6 mm², AWG 12-10
- small: for cables from 1-2,5 mm², AWG 18-14

In order to accommodate larger PE conductor cross-sectional area, use CGT PE adapters, see page 122.

position of modules (contact side view)

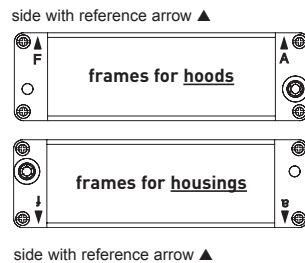

CX CFM (lock-in tab)

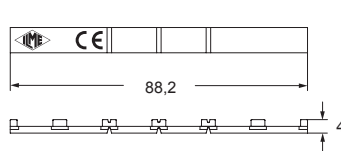

Polarisation of frames with relative identification letters and couplings

frame for hoods ¹⁾

frames for housings ¹⁾

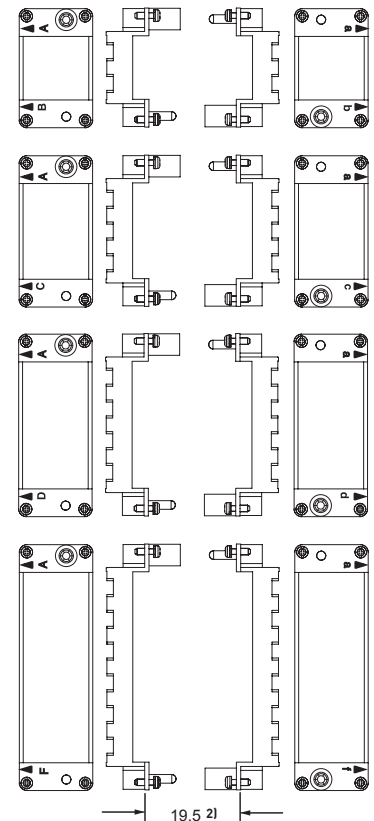

¹⁾ Warning:

- The module support frames are marked:
- FOR HOODS: **upper-case A-B, A-C, A-D and A-F**
- FOR HOUSINGS: **lower-case a-b, a-c, a-d and a-f**

Positioning the modules in the frames according to the respective letters is ensuring the specular assembly of modules, for which the hood will be coupled correctly to the housing.

²⁾ Distance for:

- electric and fibre optic contacts: max 21 mm
- pneumatic contacts: max 20,5 mm

CX 42 DF/DM 42 poles 10A - 150V High Number of Matings

The modular inserts must be installed in suitable frames which are then mounted in traditional housings * or COB panel support.

frames for modular units *

page:
51

* enclosures: bulkhead mounting housings, high construction housings or high construction hoods

modular units,
crimp connections

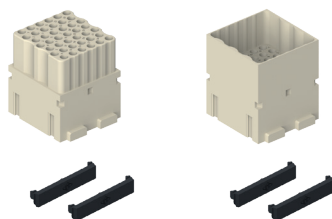

Q 10.000 MATINGS WITH HNM FRAMES AND HNM ENCLOSURES
Q 5.000 MATINGS WITH HNM FRAMES AND STANDARD ENCLOSURES, SINGLE LEVER

FROM MAY 2019

10A crimp contacts
gold plated



description	part No.	part No
-------------	----------	---------

without contacts (to be ordered separately), supplied with 2 dedicated black coloured 2-slot sized lock-in tab female inserts for female contacts
male inserts for male contacts

CX 42 DF
CX 42 DM

10A female contacts

0,14-0,37 mm ²	AWG 26-22	identification No. 1
0,5 mm ²	AWG 20	identification No. 2
0,75 mm ²	AWG 18	identification No. ②
1 mm ²	AWG 18	identification No. 3
1,5 mm ²	AWG 16	identification No. 4
2,5 mm ²	AWG 14	identification No. 5

RDF2D 0.3
RDF2D 0.5
RDF2D 0.7
RDF2D 1.0
RDF2D 1.5
RDF2D 2.5

gold plated⁺

10A male contacts

0,14-0,37 mm ²	AWG 26-22	identification No. 1
0,5 mm ²	AWG 20	identification No. 2
0,75 mm ²	AWG 18	identification No. ②
1 mm ²	AWG 18	identification No. 3
1,5 mm ²	AWG 16	identification No. 4
2,5 mm ²	AWG 14	identification No. 5

RDM2D 0.3
RDM2D 0.5
RDM2D 0.7
RDM2D 1.0
RDM2D 1.5
RDM2D 2.5

- characteristics according to EN 61984:
- 10A 150V 2,5kV 3**
- cURus, CSA, CQC, DNV-GL, BV, EAC pending
- rated voltage according to UL/CSA: 250V
- insulation resistance: ≥ 10 GΩ
- ambient temperature limit: -40 °C ... +125 °C
- made of self-extinguishing thermoplastic resin UL 94V-0
- mechanical life: ≥ 10.000 cycles
- contact resistance: ≤ 3 mΩ
- **it is recommended to crimp the contacts with crimping tools homologated by ILME** (please see the crimping tool section 10A contacts, RDF2D and RDM2D series) on pages 531-539 and 544-549 of CN.16 catalogue
- supplied with dedicated black coloured 2-slot sized lock-in tab (2, one per each side)
- for spare lock-in tab **CX CFMD** see SPARE SPARTS catalogue

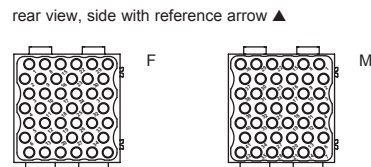
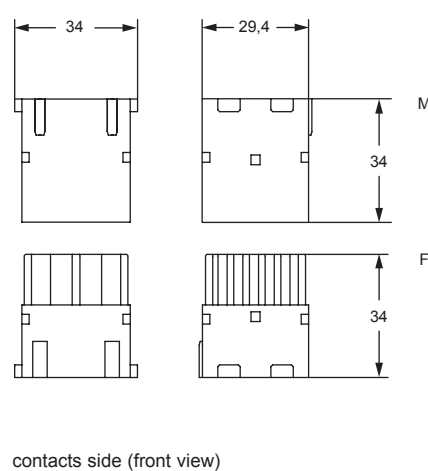

- 2 frame slots

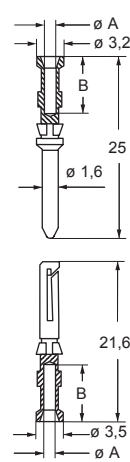

RDF2D and RDM2D contacts

conductor cross-sectional area mm ²	conductor slot ø A (mm)	conductor stripping length B (mm)
0,14-0,37	0,9	8
0,5	1,1	8
0,75	1,3	8
1,0	1,45	8
1,5	1,8	8
2,5	2,2	6

⁺ for basic or high thickness gold plating, please refer to page 480 of CN.16 catalogue

enclosures size:		page:
"44.27"	HNM	90 - 91 *
	C-TYPE IP65/IP66, single lever	240 - 243
	V-TYPE IP65/IP66, single lever	284 - 286
	E-Xtreme® corrosion proof	42 - 43, 55, 62 - 63 *
"57.27"	HNM	92 - 93 *
	C-TYPE IP65/IP66, single lever	244 - 249
	V-TYPE IP65/IP66, single lever	288 - 291
	E-Xtreme® corrosion proof	44 - 45, 56, 64 - 65 *
"77.27"	HNM	94 - 95 *
	C-TYPE IP65/IP66, single lever	250 - 256
	V-TYPE IP65/IP66, single lever	292 - 295
	E-Xtreme® corrosion proof	46 - 47, 57, 66 - 67 *
"104.27"	HNM	96 - 97 *
	C-TYPE IP65/IP66, single lever	258 - 266
	V-TYPE IP65/IP66, single lever	296 - 299
	E-Xtreme® corrosion proof	48-49, 58, 68 - 69 *
"77.62"	C-TYPE IP65/IP66, single lever	267 - 270
	E-Xtreme® corrosion proof	59 *
"104.62"	C-TYPE IP65/IP66, single lever	267 - 270
	E-Xtreme® corrosion proof	60 *

* refer to NEWS 2017 pages
 ■ refer to CN.16 pages

frames for modular units with lock-in tab (included)

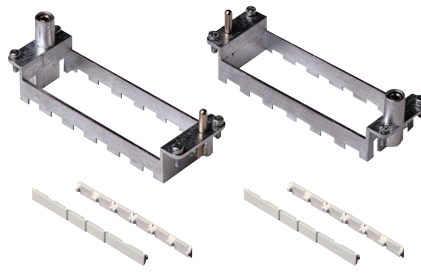

- Q 10.000 MATINGS WITH HNM INSERTS AND HNM ENCLOSURES
- Q 5.000 MATINGS WITH HNM INSERTS AND STANDARD ENCLOSURES, SINGLE LEVER

description	part No.
-------------	----------

frames for modular units with lock-in tab included
 for 2 modular units - for housing size 44.27
 for 3 modular units - for housing size 57.27
 for 4 modular units - for housing size 77.27 and 77.62
 for 6 modular units - for housing size 104.27 and 104.62

type for hoods	type for housings
RX 02 TM	RX 02 TF
RX 03 TM	RX 03 TF
RX 04 TM	RX 04 TF
RX 06 TM	RX 06 TF

✎ C-TYPE and V-TYPE 2-lever versions cannot be used to reach 5.000 matings.

- die-cast zinc alloy frames
- protective earth (PE)
- possibility of mounting female and male modular units on the same frame
- frames supplied with lock-in tab to attach units
- polarisation on frames
- coding pins **CR..CX**
- for spare lock-in tab **CX CFM** see SPARE SPARTS catalogue

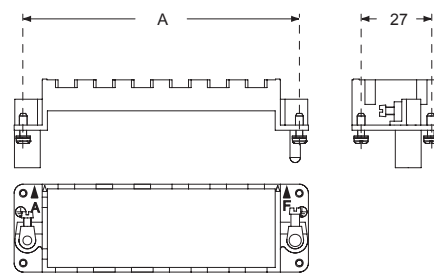

part No.	A (mm)	for housings size
RX 02 TM / TF	44	44,27
RX 03 TM / TF	57	57,27
RX 04 TM / TF	77,5	77,27 and 77,62
RX 06 TM / TF	104	104,27 and 104,62

Earth terminal
 - large: for cables from 4-6 mm², AWG 12-10
 - small: for cables from 1-2,5 mm², AWG 18-14

✎ In order to accommodate larger PE conductor cross-sectional area, use CGT PE adapters, see page 122.

position of modules (contact side view)

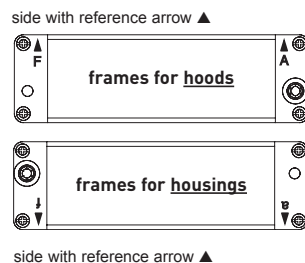

CX CFM (lock-in tab)

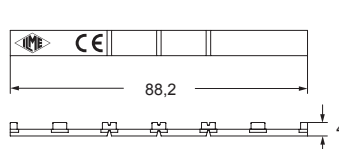

Polarisation of frames with relative identification letters and couplings

frame for hoods ¹⁾ frames for housings ¹⁾

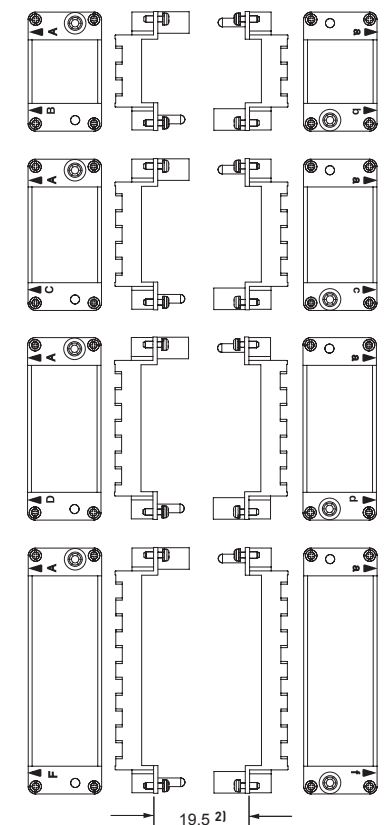

1) Warning:

- The module support frames are marked:
- FOR HOODS: **upper-case A-B, A-C, A-D and A-F**
- FOR HOUSINGS: **lower-case a-b, a-c, a-d and a-f**

Positioning the modules in the frames according to the respective letters is ensuring the specular assembly of modules, for which the hood will be coupled correctly to the housing.

2) Distance for:

- electric and fibre optic contacts: max 21 mm
- pneumatic contacts: max 20,5 mm

MIXO ONE ENCLOSURES

CXA - MXA SINGLE MODULE

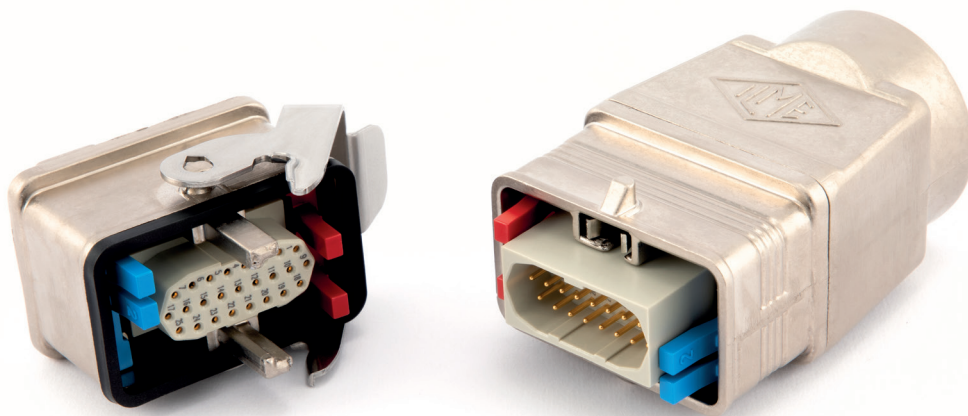

MIXO ONE
Aluminium die-cast
 housings system,
 smart solution for single-sized
 MIXO modules



Find more
information on
our products at
www.ilme.com

TECHNICAL FEATURES

CXA - MXA

MIXO ONE is the new aluminium housings system designed by ILME to accept the wide range of MIXO series single-sized modules.

These **robust connector enclosures** (3 hood variants and 1 bulkhead mounting housing) transform each single MIXO module into a **completely independent** connector.

The **MIXO ONE** enclosures incorporate a pre-leading (first-make, last-break) PE connection terminal and contact, for the safest connector operation and allow mounting of single MIXO module only in one guided way, to avoid incorrect match with the mating connector.

The pins protruding from the bulkhead mounting housing act also as key guide, in cooperation with the corresponding keyway sockets in the hoods, to avoid incorrect 180° reversed mating with corresponding connector.

Key features:

- **aluminium** die cast alloy, **nickel** plated;
- rigid **stainless steel locking lever**, releasably mounted on moulded pegs that include a stopping teeth;
- **hoods split in two parts (front, rear)**, to allow MIXO module mounting and simplify the PE connection. Supplied with four stainless steel self-threading screws and **self-retaining** sealing gasket;
- **bulkhead mounting housing** supplied with **fixing frame** for MIXO modules and **self-retaining** flange gasket;
- four optional **coding pins CR CX...** available, made by self-extinguishing thermoplastic material (UL 94V-0) for up to **16 different codings**, as a provision against mismatching when identical connectors are installed side by side;
- **protection covers** for hoods and housings made in shock-proof self-extinguishing thermoplastic material (UL 94V-2) suitable for outdoor exposure, either **with pegs** (for enclosures with locking lever and sealing gasket) or **with locking lever and sealing gasket** (for enclosures with pegs) available either with eyelet-terminated string (for fastening to housings) or with loop-terminated cord (for fastening to hoods, around the incoming cable).

robust and compact design for a new modules concept



bulkhead mounting housing with single lever

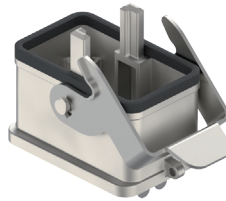

FROM SEPTEMBER 2019

hoods with 2 pegs



FROM SEPTEMBER 2019

description

part No.

part No.

entry
M

with lever

CXA 01 I

with pegs, side entry (in 2 parts)

MXA 01 O25 25

with pegs, top entry (in 2 parts)

MXA 01 V25 25

with pegs, top entry (in 2 parts)

MXA 01 V32 32

CXA I

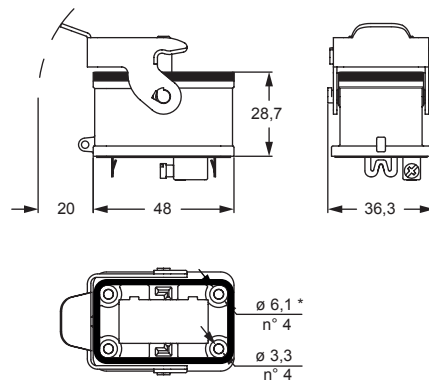

* for M3 fixing screws (not supplied) with maximum 6 mm head diameter

panel cut-out for bulkhead mounting housings

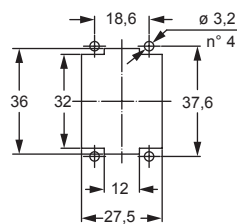

MXA 025

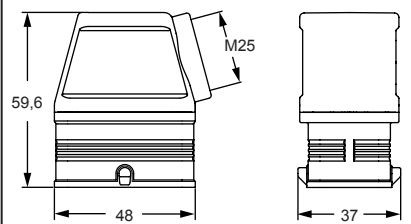

MXA V25

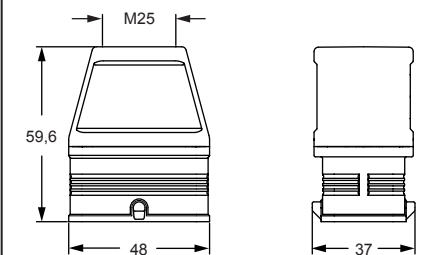

MXA V32

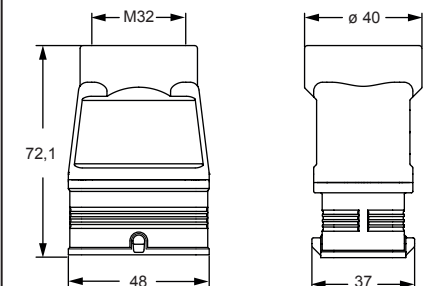

cURus
Type 4/4X/12 pending



according to IEC/EN 60529



Watch
our
video

plastic covers

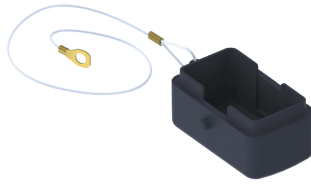

FROM SEPTEMBER 2019

plastic covers with lever and gasket

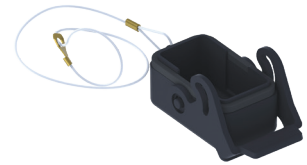

FROM SEPTEMBER 2019

description

part No.
(with eyelet)

part No.
(with loop)

with 2 pegs (for enclosures with 1 lever with gasket)
with 1 lever and gasket (for hoods with 2 pegs)

CXP 01 C

CXP 01 CLG

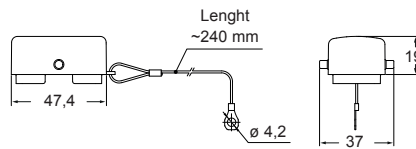

For fixing on housings

eyelet

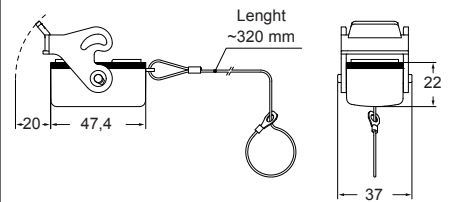
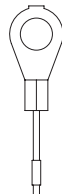

For fixing on hoods

loop

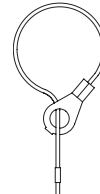

cURus
Type 4/4X/12 pending



according to IEC/EN 60529

CR CX coding pins

coding pins

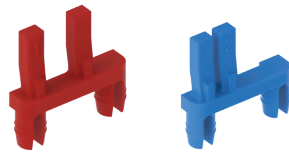

FROM SEPTEMBER 2019

coding pins



FROM SEPTEMBER 2019

description

part No.

part No.

red coding pin (#1)

CR CX01R

blue coding pin (#2)

CR CX01B

yellow coding pin (#3)

CR CX01G

black coding pin (#4)

CR CX01N

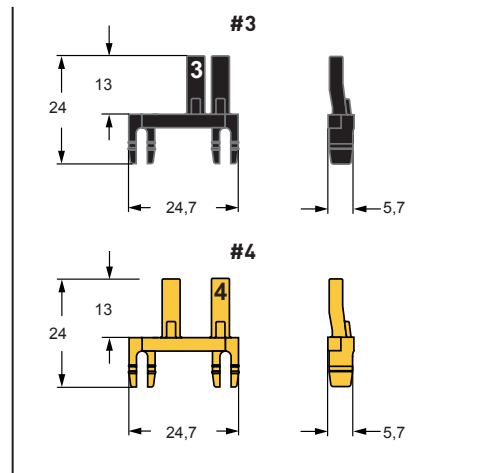
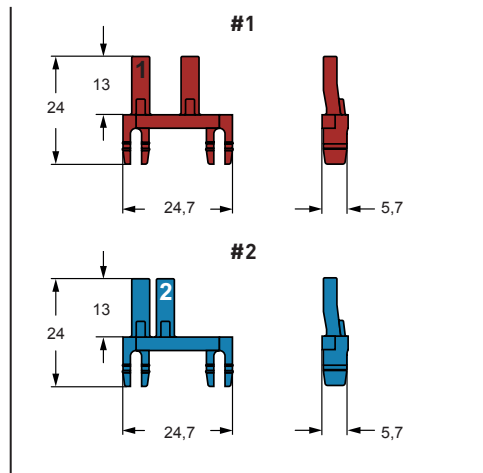

CR CX01 CODING OPTIONS

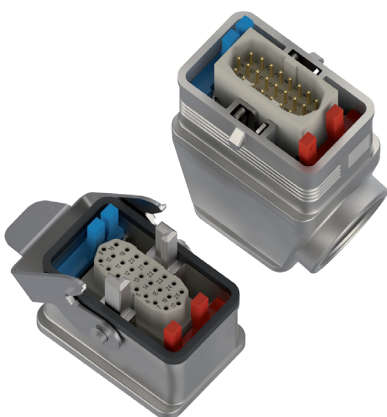

Example of coding option **6** of 16 different codings possible (4 coding pins per each connector coupling)



ASSEMBLY INSTRUCTIONS

MIXO ONE BULKHEAD HOUSING

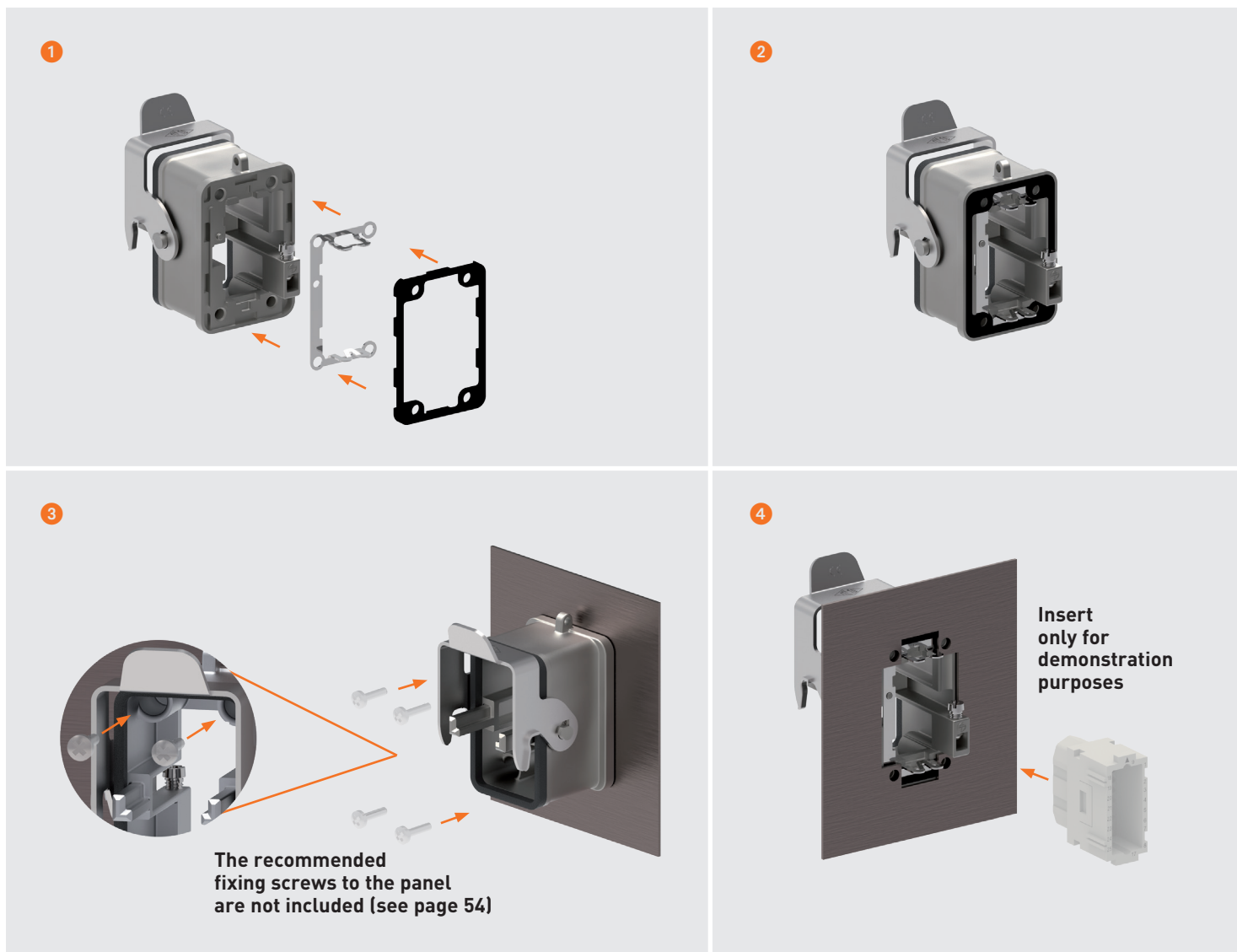

MIXO ONE HOODS

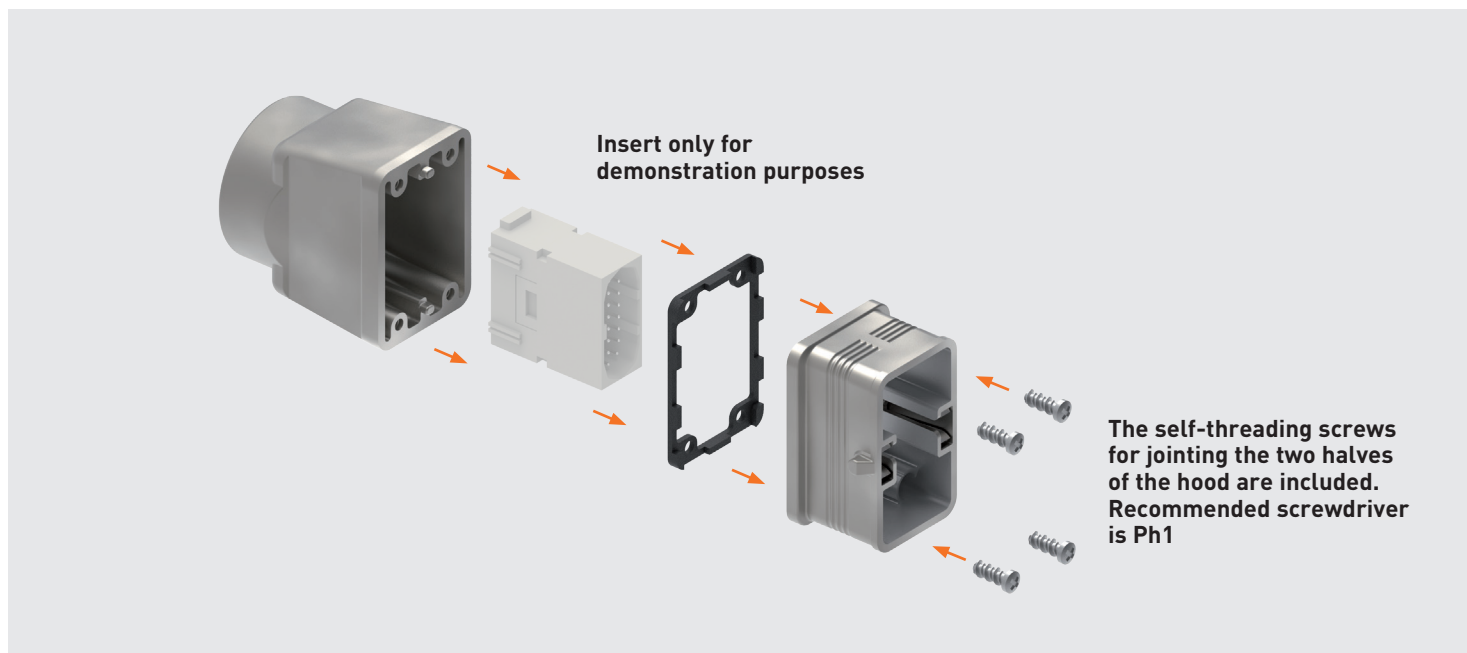

METAL HOUSINGS

MKA IF size "21.21"

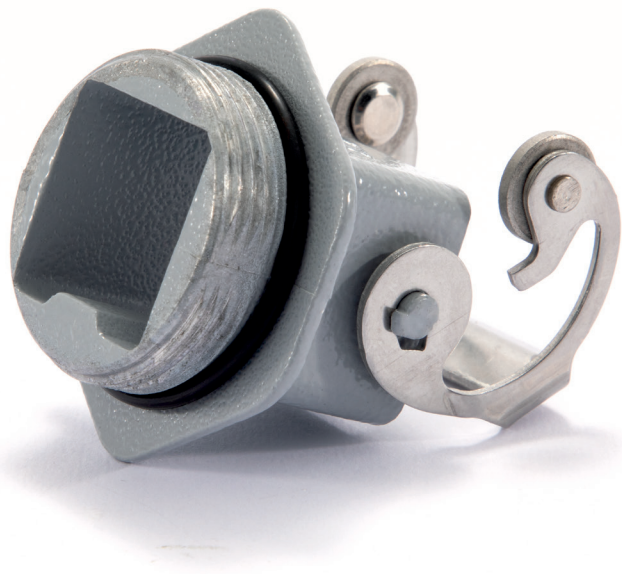

"21.21" size
metal bulkhead
connector housings,
with M32 male
threaded appendix



Find more
information on
our products at
www.ilme.com

TECHNICAL FEATURES

MKA IF

- metal bulkhead connector housing for all connector inserts size "21.21" **with round M32 male threaded appendix** underneath the flange, to be fixed to an M32 threaded hole on a panel;
- possibility of panel mounting by means of a plain, unthreaded hole, by an M32 counter nut (to be provided separately);
- full compatibility with all the existing range of size "21.21" hoods;
- available with all variants of locking lever:
 - I** = standard rigid galvanized steel;
 - X** = "Class" stainless steel with rolls;
 - XX** = rigid stainless steel;
- in **standard, W-Type** (aggressive environment), **EMC** (improved shielding effectiveness) and **180 °C** (high temperatures) versions.

round
M32 male
threaded
appendix

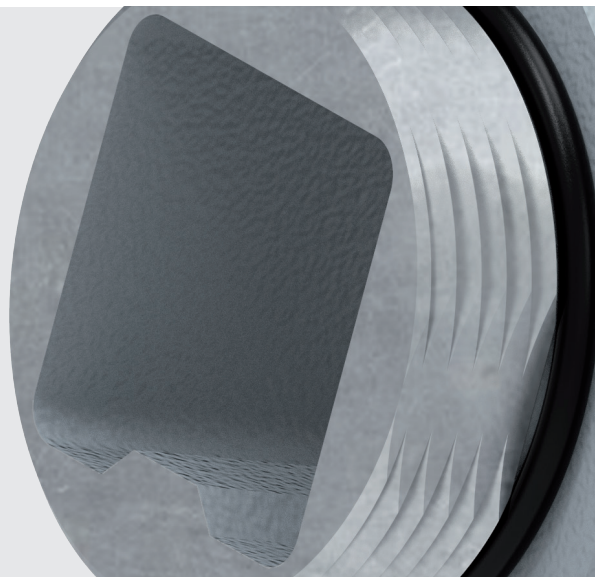

MKAX standard metallic version

inserts

CK	3 and 4 poles + ⊕	48
CKS	3 and 4 poles + ⊕	49
CKSH	3 and 4 poles + ⊕	7 **
CD	8 poles	54
CQ4	2 poles + ⊕	32 ***
CQ4	3 poles + ⊕	23 *
CQ	5 poles + ⊕	166
CQ	7 poles + ⊕	8 **
CQ	12 poles + ⊕	165
CQ	21 poles + ⊕	11 **
CJ KF		503
CJK 8FT		506
CLK 04 SC		509
CX 1/2 BD		512
CXL 2/4 SF/SM		524
CXL SF/SM		524
CXL 2/4 PF/PM		525
CXL 2/4 PFH/PMH		525
CXL PF/PM		525

page:

bulkhead mounting housings



STAINLESS STEEL LEVER

FROM MAY 2019

* refer to NEWS 2016 pages
 ** refer to NEWS 2017 pages
 *** refer to 2019 Multipole connectors pages
 refer to CN.16 pages

description

part No.
(entry M32)

M32 fixing thread ^{1) 1)}

MKAX IF

gasket and screw kit for IP66/IP67/IP69 ¹⁾

CKR 65

gasket and screw kit for IP66/IP67/IP69 ¹⁾ specific for CD 08 inserts

CKR 65 D

1) To obtain the IP66/IP67/IP69 degree of protection, a kit with insert fixing screw and gasket can be purchased separately. Several inserts size "21.21" are already supplied with fixing screw and gasket, which ensures IP66/IP67/IP69 degree of protection. See list below, not including any special version:

- CQF/M 07, CQF/M 12
- CJ KF/M
- CJK 8FT /8IFT /8MT /8IMT, CJK 8M
- CUK 2FT /3FT
- CX 1/2 BDF/M
- CLK 04 SCF /SCF-H /SCM
- CXL 2/4 PF /PM /PFH /PMH /SF /SM, CXL SF/M

NOTE: Housing type and colour may vary upon specific part No.

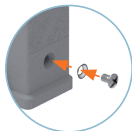

¹⁾ Locknut supplied on request, see Cable glands catalogue (article AS M32N metallic).

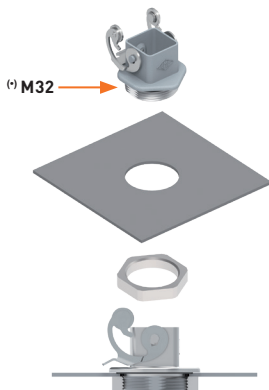

NOTE: Lever type and housing colour may vary upon specific part No.

cURus
Type 4/4X/12 pending



IP66/IP67/IP69 with CKR 65 (D) ¹⁾

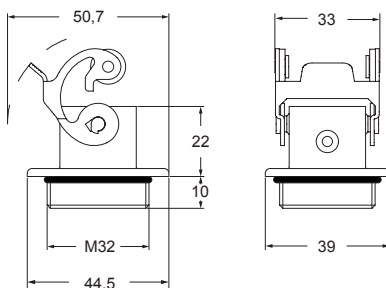

panel cut-out for enclosures

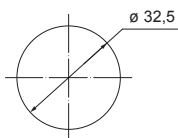

MKA - MKAXX standard metallic version

inserts

CK	3 and 4 poles + ⊕	48
CKS	3 and 4 poles + ⊕	49
CKSH	3 and 4 poles + ⊕	7 **
CD	8 poles	54
CQ4	2 poles + ⊕	32 ***
CQ4	3 poles + ⊕	23 *
CQ	5 poles + ⊕	166
CQ	7 poles + ⊕	8 **
CQ	12 poles + ⊕	165
CQ	21 poles + ⊕	11 **
CJ KF		503
CJK 8FT		506
CLK 04 SC		509
CX 1/2 BD		512
CXL 2/4 SF/SM		524
CXL SF/SM		524
CXL 2/4 PF/PM		525
CXL 2/4 PFH/PMH		525
CXL PF/PM		525

* refer to NEWS 2016 pages
 ** refer to NEWS 2017 pages
 *** refer to 2019 Multipole connectors pages
 ■ refer to CN.16 pages

page:

bulkhead mounting housings



GALVANIZED STEEL RIGID LEVER
FROM MAY 2019

bulkhead mounting housings



STAINLESS STEEL RIGID LEVER
FROM MAY 2019

description

part No.
(entry M32)

part No.
(entry M32)

M32 fixing thread ^{1) (1)}

MKA IF

M32 fixing thread ^{1) (1)}

MKAXX IF

gasket and screw kit
for IP66/IP67/IP69 ¹⁾

CKR 65

CKR 65

gasket and screw kit for IP66/IP67/IP69 ¹⁾
specific for CD 08 inserts

CKR 65 D

CKR 65 D

¹⁾ To obtain the IP66/IP67/IP69 degree of protection, a kit with insert fixing screw and gasket can be purchased separately.

Several inserts size "21.21" are already supplied with fixing screw and gasket, which ensures IP66/IP67/IP69 degree of protection. See list below, not including any special version:

- CQF/M 07, CQF/M 12
- CJ KF/M
- CJK 8FT /8IFT /8MT /8IMT, CJK 8M
- CUK 2FT /3FT
- CX 1/2 BDF/M
- CLK 04 SCF /SCF-H /SCM
- CXL 2/4 PF /PM /PFH /PMH /SF /SM, CXL SF/M

NOTE: Housing type and colour may vary upon specific part No.

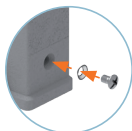

⁽¹⁾ Locknut supplied on request, see Cable glands catalogue (article AS M32N metallic).

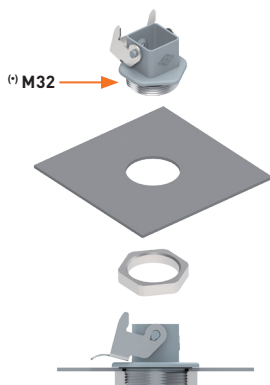

NOTE: Lever type and housing colour may vary upon specific part No.

cURus
Type 4/4X/12 pending



IP44/IP66/IP67/IP69 with CKR 65 (D) ¹⁾

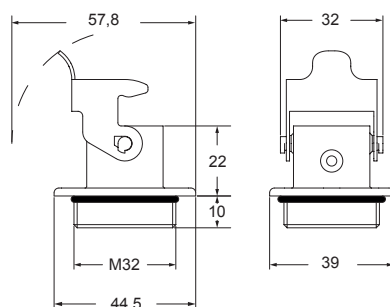

panel cut-out for enclosures

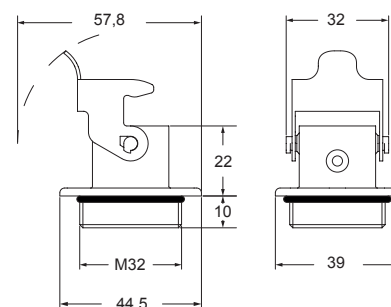
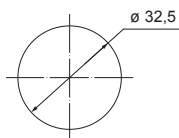

panel cut-out for enclosures

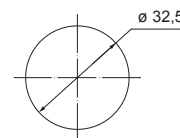

MKAXW for aggressive environments

inserts

CK	3 and 4 poles + ⊕	48
CKS	3 and 4 poles + ⊕	49
CKSH	3 and 4 poles + ⊕	7 **
CD	8 poles	54
CQ4	2 poles + ⊕	32 ***
CQ4	3 poles + ⊕	23 *
CQ	5 poles + ⊕	166
CQ	7 poles + ⊕	8 **
CQ	12 poles + ⊕	165
CQ	21 poles + ⊕	11 **
CJ KF		503
CJK 8FT		506
CLK 04 SC		509
CX 1/2 BD		512
CXL 2/4 SF/SM		524
CXL SF/SM		524
CXL 2/4 PF/PM		525
CXL 2/4 PFH/PMH		525
CXL PF/PM		525

page:

bulkhead mounting housings



STAINLESS STEEL LEVER

FROM MAY 2019

* refer to NEWS 2016 pages
 ** refer to NEWS 2017 pages
 *** refer to 2019 Multipole connectors pages
 refer to CN.16 pages

description	part No. (entry M32)
M32 fixing thread ⁽¹⁾	MKAXW IF
gasket and screw kit for IP66/IP67/IP69 ¹⁾	CKR 65
gasket and screw kit for IP66/IP67/IP69 ¹⁾ specific for CD 08 inserts	CKR 65 D

¹⁾ To obtain the IP66/IP67/IP69 degree of protection, a kit with insert fixing screw and gasket can be purchased separately. Several inserts size "21.21" are already supplied with fixing screw and gasket, which ensures IP66/IP67/IP69 degree of protection. See list below, not including any special version:

- CQF/M 07, CQF/M 12
- CJ KF/M
- CJK 8FT /8IFT /8MT /8IMT, CJK 8M
- CUK 2FT /3FT
- CX 1/2 BDF/M
- CLK 04 SCF /SCF-H /SCM
- CXL 2/4 PF /PM /PFH /PMH /SF /SM, CXL SF/M

NOTE: Housing type and colour may vary upon specific part No.

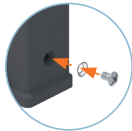

⁽¹⁾ Locknut supplied on request, see Cable glands catalogue (article AS M32N metallic).

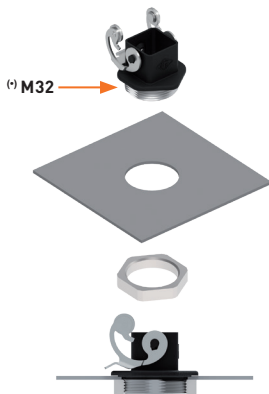

NOTE: Lever type and housing colour may vary upon specific part No.

cURus
 Type 4/4X/12 pending

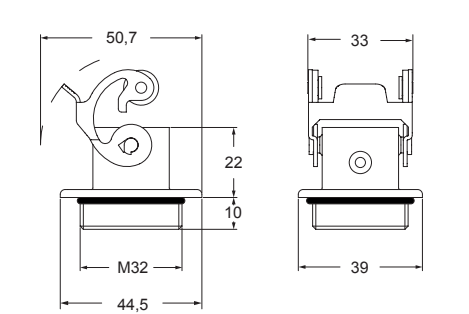
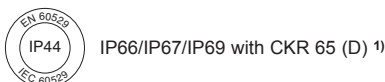

panel cut-out for enclosures

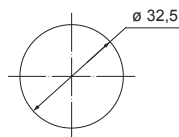

MKAXXW for aggressive environments

inserts

CK	3 and 4 poles + ⊕	48
CKS	3 and 4 poles + ⊕	49
CKSH	3 and 4 poles + ⊕	7 **
CD	8 poles	54
CQ4	2 poles + ⊕	32 ***
CQ4	3 poles + ⊕	23 *
CQ	5 poles + ⊕	166
CQ	7 poles + ⊕	8 **
CQ	12 poles + ⊕	165
CQ	21 poles + ⊕	11 **
CJ KF		503
CJK 8FT		506
CLK 04 SC		509
CX 1/2 BD		512
CXL 2/4 SF/SM		524
CXL SF/SM		524
CXL 2/4 PF/PM		525
CXL 2/4 PFH/PMH		525
CXL PF/PM		525

page:

bulkhead mounting housings



STAINLESS STEEL RIGID LEVER

FROM MAY 2019

* refer to NEWS 2016 pages
 ** refer to NEWS 2017 pages
 *** refer to 2019 Multipole connectors pages
 refer to CN.16 pages

description	part No. (entry M32)
M32 fixing thread ⁽¹⁾	MKAXXW IF
gasket and screw kit for IP66/IP67/IP69 ¹⁾	CKR 65
gasket and screw kit for IP66/IP67/IP69 ¹⁾ specific for CD 08 inserts	CKR 65 D

1) To obtain the IP66/IP67/IP69 degree of protection, a kit with insert fixing screw and gasket can be purchased separately. Several inserts size "21.21" are already supplied with fixing screw and gasket, which ensures IP66/IP67/IP69 degree of protection. See list below, not including any special version:

- CQF/M 07, CQF/M 12
- CJ KF/M
- CJK 8FT /8IFT /8MT /8IMT, CJK 8M
- CUK 2FT /3FT
- CX 1/2 BDF/M
- CLK 04 SCF /SCF-H /SCM
- CXL 2/4 PF /PM /PFH /PMH /SF /SM, CXL SF/M

NOTE: Housing type and colour may vary upon specific part No.

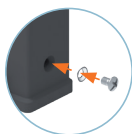

⁽¹⁾ Locknut supplied on request, see Cable glands catalogue (article AS M32N metallic).

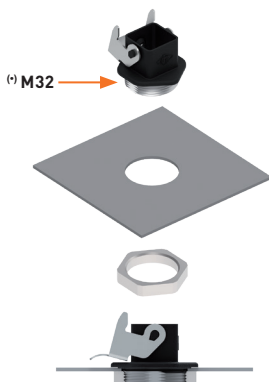

NOTE: Lever type and housing colour may vary upon specific part No.

cURus
 Type 4/4X/12 pending



IP44 IP66/IP67/IP69 with CKR 65 (D) ¹⁾

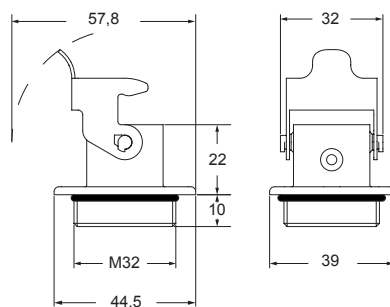

panel cut-out for enclosures

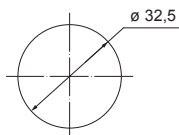

MKAXS EMC version for electromagnetic compatibility

inserts

CK	3 and 4 poles + ⊕	48
CKS	3 and 4 poles + ⊕	49
CKSH	3 and 4 poles + ⊕	7 **
CD	8 poles	54
CQ4	2 poles + ⊕	32 ***
CQ4	3 poles + ⊕	23 *
CQ	5 poles + ⊕	166
CQ	7 poles + ⊕	8 **
CQ	12 poles + ⊕	165
CQ	21 poles + ⊕	11 **
CJ KF		503
CJK 8FT		506
CLK 04 SC		509
CX 1/2 BD		512
CXL 2/4 SF/SM		524
CXL SF/SM		524
CXL 2/4 PF/PM		525
CXL 2/4 PFH/PMH		525
CXL PF/PM		525

page:

bulkhead mounting housings



STAINLESS STEEL LEVER
FROM MAY 2019

* refer to NEWS 2016 pages
 ** refer to NEWS 2017 pages
 *** refer to 2019 Multipole connectors pages
 refer to CN.16 pages

description	part No. (entry M32)
-------------	-------------------------

M32 fixing thread ⁽¹⁾	MKAXS IF
gasket and screw kit for IP66/IP67/IP69 ¹⁾	CKR 65
gasket and screw kit for IP66/IP67/IP69 ¹⁾ specific for CD 08 inserts	CKR 65 D

1) To obtain the IP66/IP67/IP69 degree of protection, a kit with insert fixing screw and gasket can be purchased separately.
 Several inserts size "21.21" are already supplied with fixing screw and gasket, which ensures IP66/IP67/IP69 degree of protection. See list below, not including any special version:
 - CQF/M 07, CQF/M 12
 - CJ KF/M
 - CJK 8FT /8IFT /8MT /8IMT, CJK 8M
 - CUK 2FT /3FT
 - CX 1/2 BDF/M
 - CLK 04 SCF /SCF-H /SCM
 - CXL 2/4 PF /PM /PFH /PMH /SF /SM, CXL SF/M

NOTE: Housing type and colour may vary upon specific part No.

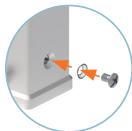

⁽¹⁾ Locknut supplied on request, see Cable glands catalogue (article AS M32N metallic).

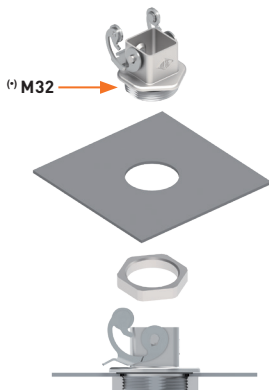

NOTE: Lever type and housing colour may vary upon specific part No.

cURus
 Type 4/4X/12 pending

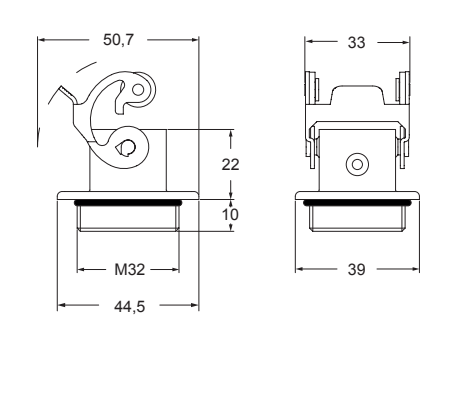
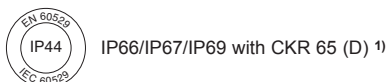

panel cut-out for enclosures

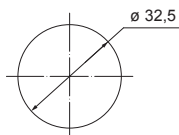

inserts		page:
CK	3 and 4 poles + ⊕	48
CKS	3 and 4 poles + ⊕	49
CKSH	3 and 4 poles + ⊕	7 **
CD	8 poles	54
CQ4	2 poles + ⊕	32 ***
CQ4	3 poles + ⊕	23 *
CQ	5 poles + ⊕	166
CQ	7 poles + ⊕	8 **
CQ	12 poles + ⊕	165
CQ	21 poles + ⊕	11 **
CJ KF		503
CJK 8FT		506
CLK 04 SC		509
CX 1/2 BD		512
CXL 2/4 SF/SM		524
CXL SF/SM		524
CXL 2/4 PF/PM		525
CXL 2/4 PFH/PMH		525
CXL PF/PM		525

* refer to NEWS 2016 pages
 ** refer to NEWS 2017 pages
 *** refer to 2019 Multipole connectors pages
 ■ refer to CN.16 pages

bulkhead mounting housings



GALVANIZED STEEL RIGID LEVER
FROM MAY 2019

bulkhead mounting housings



STAINLESS STEEL RIGID LEVER
FROM MAY 2019

description	part No. (entry M32)	part No. (entry M32)
M32 fixing thread ⁽¹⁾	MKAS IF	
M32 fixing thread ⁽¹⁾		MKAXXS IF
gasket and screw kit for IP66/IP67/IP69 ⁽¹⁾	CKR 65	CKR 65
gasket and screw kit for IP66/IP67/IP69 ⁽¹⁾ specific for CD 08 inserts	CKR 65 D	CKR 65 D

⁽¹⁾ To obtain the IP66/IP67/IP69 degree of protection, a kit with insert fixing screw and gasket can be purchased separately. Several inserts size "21.21" are already supplied with fixing screw and gasket, which ensures IP66/IP67/IP69 degree of protection. See list below, not including any special version:

- CQF/M 07, CQF/M 12
- CJ KF/M
- CJK 8FT /8IFT /8MT /8IMT, CJK 8M
- CUK 2FT /3FT
- CX 1/2 BDF/M
- CLK 04 SCF /SCF-H /SCM
- CXL 2/4 PF /PM /PFH /PMH /SF /SM, CXL SF/M

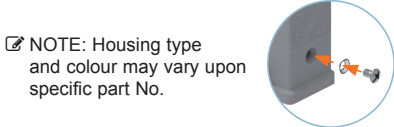

⁽¹⁾ Locknut supplied on request, see Cable glands catalogue (article AS M32N metallic).

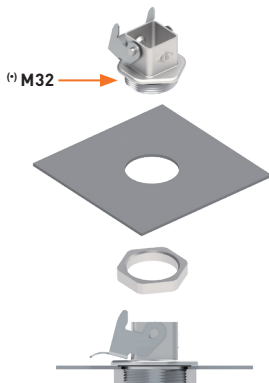

NOTE: Lever type and housing colour may vary upon specific part No.

cURus
 Type 4/4X/12 pending

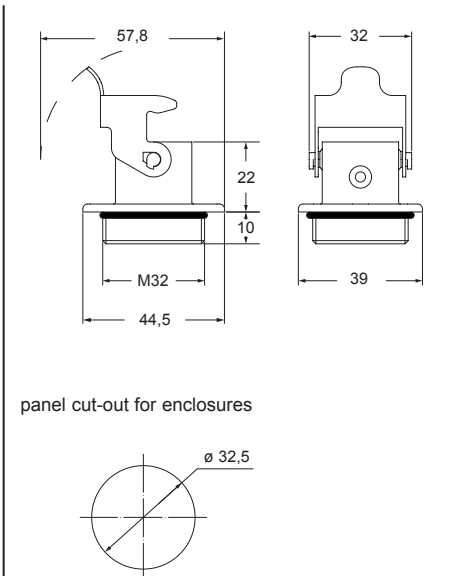
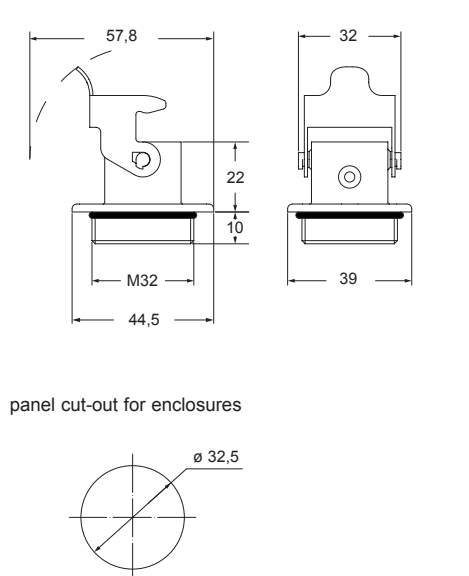
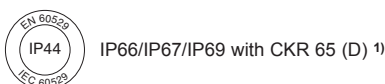

MKAXR 180 °C version

inserts

CK RY	3 poles + ⊕	51
CK RY	4 poles + ⊕	51

page:

bulkhead mounting housings



STAINLESS STEEL LEVER

FROM MAY 2019

refer to CN.16 pages

description

part No.
(entry M32)

M32 fixing thread ^(*)

MKAXR IF

^(*) Locknut supplied on request, see Cable glands catalogue (article AS M32N metallic).

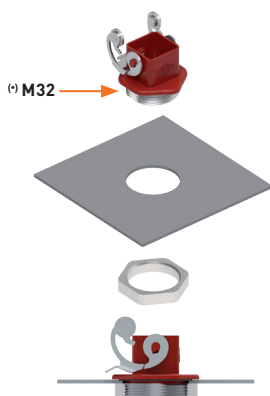

NOTE: Lever type and housing colour may vary upon specific part No.

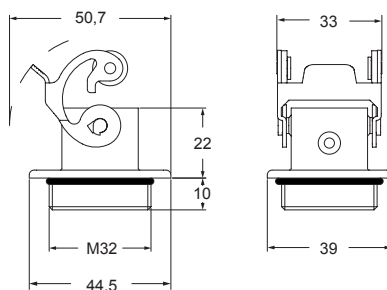

panel cut-out for enclosures

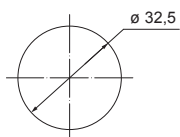

cURus
Type 12 pending



inserts		page:
CK RY	3 poles + ⊕	51
CK RY	4 poles + ⊕	51

bulkhead mounting housings



STAINLESS STEEL RIGID LEVER
FROM MAY 2019

refer to CN.16 pages

description

part No.
(entry M32)

M32 fixing thread ^(*)

MKAXXR IF

^(*) Locknut supplied on request, see Cable glands catalogue (article AS M32N metallic).

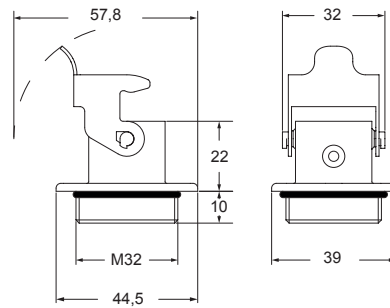
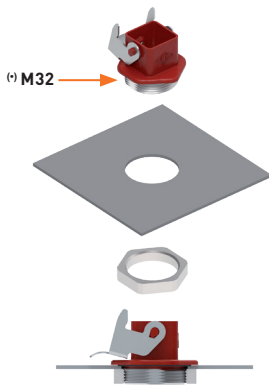

panel cut-out for enclosures

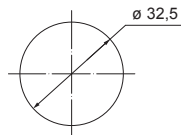

NOTE: Lever type and housing colour may vary upon specific part No.

cURus
Type 12 pending



BULKHEAD MOUNTING HOUSINGS SIZE "21.21" EMC VERSION FOR ELECTROMAGNETIC COMPATIBILITY

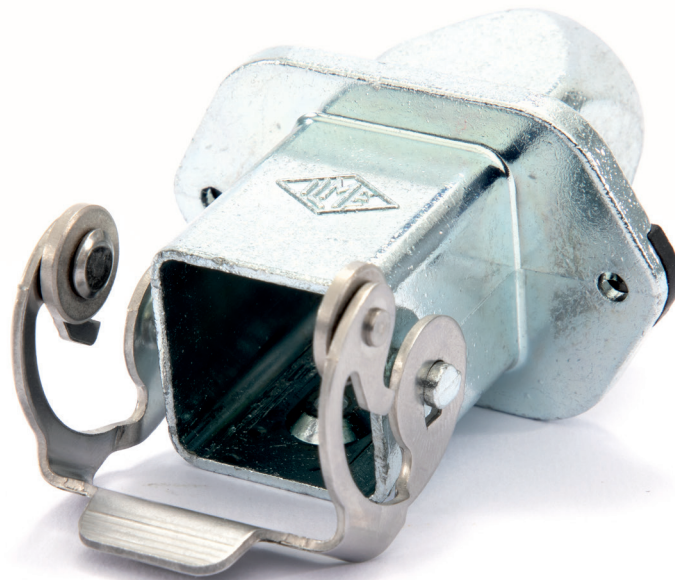

MKAS IVG20
size "21.21"
for bulkhead mounting
with additional flange



Find more
information on
our products at
www.ilme.com

TECHNICAL FEATURES

MKAS IVG20 size “21.21”

- special zinc alloy die cast hood with additional flange for the **bulkhead mounting** to a cabinet wall, for all connector inserts size “21.21”;
- provides **full shielding** not only outside the cabinet, but also **inside the cabinet**, for very sensitive applications;
- **captively built-in flange sealing/gasket** allowing direct contact between metal flange and metal mounting surface. Good EMC shielding granted without the need of conductive sealing material;
- **EMC type** (with conductive surface);
- **M20 rear cable entry**;
- **stainless steel “Class” locking lever** with rolls;
- full compatibility with all the existing range of size “21.21” hoods;
- upon request, also available in several variants that differ by:
 - **locking lever material** (galvanized steel, by RoHS 2 conform electroplating, or stainless steel - “X” in the code - same rigid geometry but different corrosion resistance);
 - **locking lever stiffness:**
 - **resilient**, “Class” type with rolls, preferable for frequent disconnection and moderate mechanical load from the cable;
 - **rigid**, for higher mechanical load from the cable and less frequently expected operations;
 - **corrosion resistance:** W-Type versions, for aggressive environments;
 - **EMC shielding:** S-Type, with conductive surface (to be combined with use of EMC cable gland).

full shielding also inside the cabinet for very sensitive applications (using EMC cable gland)

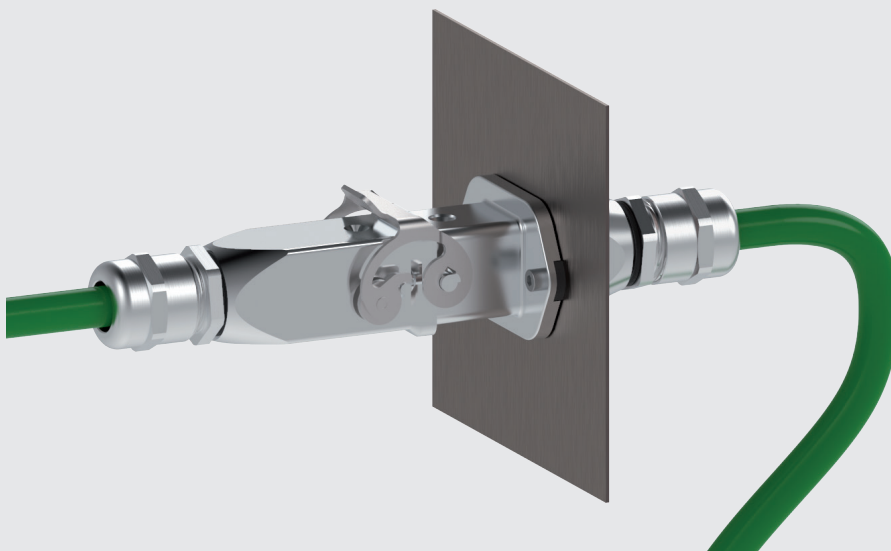

MKAXS EMC version for electromagnetic compatibility

inserts		page:
CK	3 and 4 poles + ⊕	48
CKS	3 and 4 poles + ⊕	49
CKSH	3 and 4 poles + ⊕	7 **
CD	8 poles	54
CQ4	2 poles + ⊕	32 ***
CQ4	3 poles + ⊕	23 *
CQ	5 poles + ⊕	166
CQ	7 poles + ⊕	8 **
CQ	12 poles + ⊕	165
CQ	21 poles + ⊕	11 **
CJ KF		503
CJK 8FT		506
CLK 04 SC		509
CX 1/2 BD		512
CXL 2/4 PF/PM		525
CXL 2/4 PFH/PMH		525
CXL PF/PM		525

* refer to NEWS 2016 pages
 ** refer to NEWS 2017 pages
 *** refer to 2019 Multipole connectors pages
 ■ refer to CN.16 pages

bulkhead mounting housings

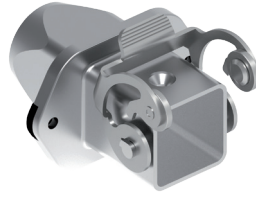

STAINLESS STEEL LEVER
FROM MARCH 2019

description	part No. (entry M20)
M20 cable entry 1)	MKAXS IVG20
gasket and screw kit for IP66/IP67/IP69 1)	CKR 65
gasket and screw kit for IP66/IP67/IP69 1) specific for CD 08 inserts	CKR 65 D

1) To obtain the IP66/IP67/IP69 degree of protection, a kit with insert fixing screw and gasket can be purchased separately.
 Several inserts size "21.21" are already supplied with fixing screw and gasket, which ensures IP66/IP67/IP69 degree of protection. See list below, not including any special version:

- CQF/M 07, CQF/M 12
- CJ KF/M
- CJK 8FT /8IFT /8MT /8IMT, CJK 8M
- CUK 2FT /3FT
- CX 1/2 BDF/M
- CLK 04 SCF /SCF-H /SCM
- CXL 2/4 PF /PM /PFH /PMH /SF /SM, CXL SF/M

NOTE: Housing type and colour may vary upon specific part No.

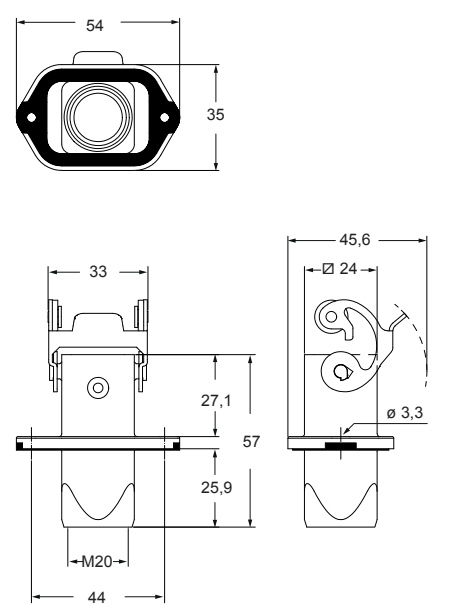
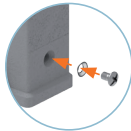

panel cut-out for enclosures

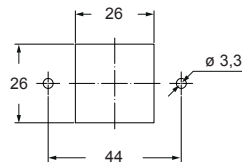

cURus
 Type 12 / Type 4/4X only with CKR 65 (D)
 pending

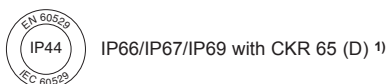

MKAS - MKAXXS EMC version for electromagnetic compatibility

inserts		page:
CK	3 and 4 poles + ⊕	48
CKS	3 and 4 poles + ⊕	49
CKSH	3 and 4 poles + ⊕	7 **
CD	8 poles	54
CQ4	2 poles + ⊕	32 ***
CQ4	3 poles + ⊕	23 *
CQ	5 poles + ⊕	166
CQ	7 poles + ⊕	8 **
CQ	12 poles + ⊕	165
CQ	21 poles + ⊕	11 **
CJ KF		503
CJK 8FT		506
CLK 04 SC		509
CX 1/2 BD		512
CXL 2/4 PF/PM		525
CXL 2/4 PFH/PMH		525
CXL PF/PM		525

* refer to NEWS 2016 pages
 ** refer to NEWS 2017 pages
 *** refer to 2019 Multipole connectors pages
 ■ refer to CN.16 pages

bulkhead mounting housings

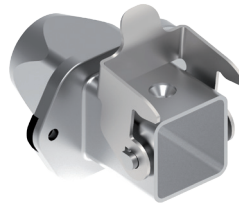

GALVANIZED STEEL RIGID LEVER
FROM MARCH 2019

bulkhead mounting housings

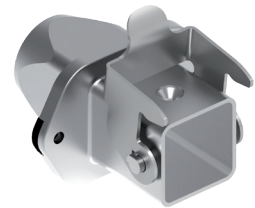

STAINLESS STEEL RIGID LEVER
FROM MARCH 2019

description	part No. (entry M20)	part No. (entry M20)
M20 cable entry ¹⁾	MKAS IVG20	
M20 cable entry ¹⁾		MKAXXS IVG20
gasket and screw kit for IP66/IP67/IP69 ¹⁾	CKR 65	CKR 65
gasket and screw kit for IP66/IP67/IP69 ¹⁾ specific for CD 08 inserts	CKR 65 D	CKR 65 D

¹⁾ To obtain the IP66/IP67/IP69 degree of protection, a kit with insert fixing screw and gasket can be purchased separately.
 Several inserts size "21.21" are already supplied with fixing screw and gasket, which ensures IP66/IP67/IP69 degree of protection. See list below, not including any special version:

- CQF/M 07, CQF/M 12
- CJ KF/M
- CJK 8FT /8IFT /8MT /8IMT, CJK 8M
- CUK 2FT /3FT
- CX 1/2 BDF/M
- CLK 04 SCF /SCF-H /SCM
- CXL 2/4 PF /PM /PFH /PMH /SF /SM, CXL SF/M

NOTE: Housing type and colour may vary upon specific part No.

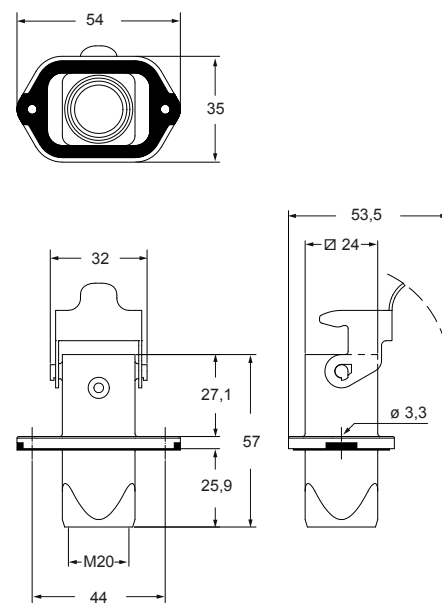
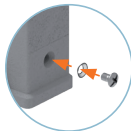

panel cut-out for enclosures

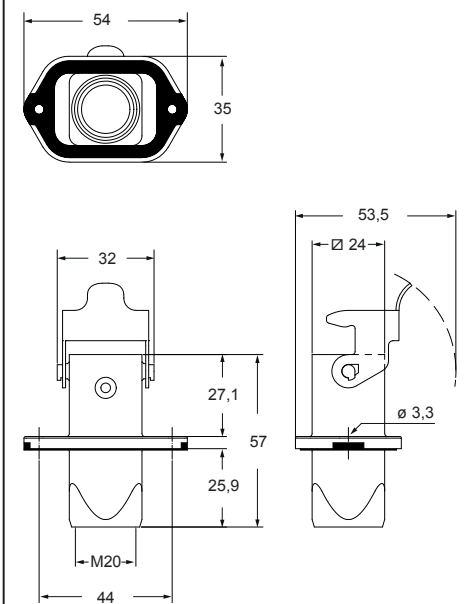
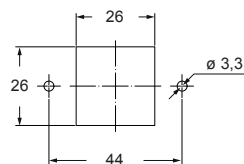

panel cut-out for enclosures

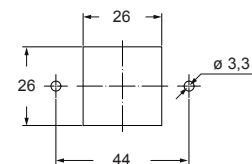

cURus
 Type 12 / Type 4/4X only with CKR 65 (D)
 pending

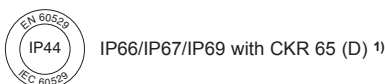

M25 INSULATING HOODS

MK - MKG



MK - MKG
insulating hoods
with M25 cable entry
size "21.21"



Find more
information on
our products at
www.ilme.com

TECHNICAL FEATURES

MK - MKG

- insulating hoods with pegs or with locking lever ("**G**" in suffix), with M25 cable entry, for all connector inserts size "21.21", light grey RAL 7035; available also in black colour RAL 9005 (suffix **VN 25**, **VGN 25**);
- suitable for the **wiring with cables with large diameter** (high conductor cross-sectional areas e.g. in combination with CQ4 40A inserts or large number of individual conductors e.g. in combination with CQ 21 inserts);
- full compatibility with all range of existing "21.21" housings;
- available also the variants **MKG** with glued sealing gasket, suitable for all male connector inserts without gasket (like CX 1/2 BDM, **CJ KM**, **CJK 8MT**, **CJK 8IMT**, **CLK 04 SCM** and DESINA® ISO 23570 conform electro/optical inserts except CXL 2/4 SF/M).

M25 cable entry,
available in light grey
RAL 7035 and black
RAL 9005 versions

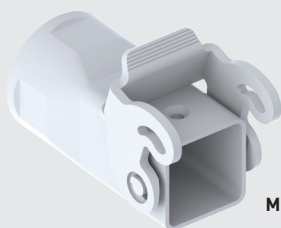

MK VG25

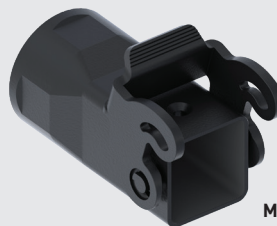

MK VGN25

MK standard insulating version

inserts		page:
CK	3 and 4 poles + ⊕	48
CKS	3 and 4 poles + ⊕	49
CKSH	3 and 4 poles + ⊕	7 **
CD	7 poles + ⊕	53
CD	8 poles	54
CQ4	2 poles + ⊕	32 ***
CQ4	3 poles + ⊕	23 *
CQ	5 poles + ⊕	166
CQ	7 poles + ⊕	8 **
CQ	12 poles + ⊕	165
CQ	21 poles + ⊕	11 **

* refer to NEWS 2016 pages
 ** refer to NEWS 2017 pages
 *** refer to 2019 Multipole connectors pages
 ■ refer to CN.16 pages

hood



FROM APRIL 2019

hood



FROM APRIL 2019

description	part No. (entry M25)	part No. (entry M25)
with pegs, top entry	MK V25 (light grey RAL 7035)	
with pegs, top entry		MK VN25 (black)
gasket and screw kit for IP66/IP67/IP69 1)	CKR 65	CKR 65
gasket and screw kit for IP66/IP67/IP69 1) specific for CD 08 inserts	CKR 65 D	CKR 65 D

1) To obtain the IP66/IP67/IP69 degree of protection, a kit with insert fixing screw and gasket can be purchased separately.
 Several inserts size "21.21" are already supplied with fixing screw and gasket, which ensures IP66/IP67/IP69 degree of protection. See list below, not including any special version:

- CQF/M 07, CQF/M 12
- CJ KF/M
- CJK 8FT /8IFT /8MT /8IMT, CJK 8M
- CUK 2FT /3FT
- CX 1/2 BDF/M
- CLK 04 SCF /SCF-H /SCM
- CXL 2/4 PF /PM /PFH /PMH /SF /SM, CXL SF/M

NOTE: Housing type and colour may vary upon specific part No.

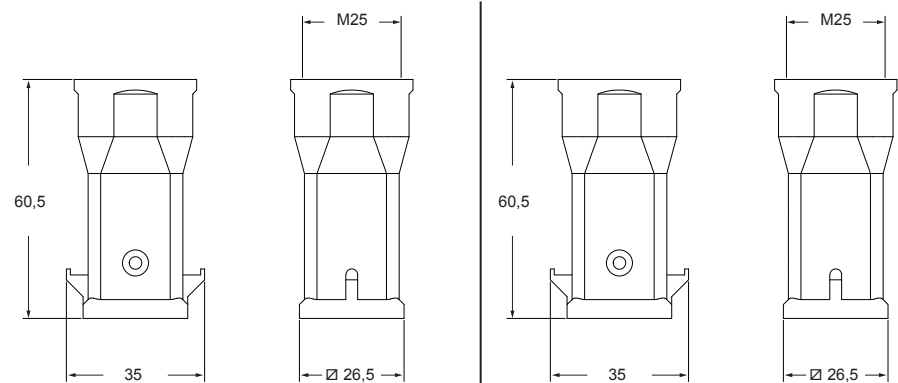
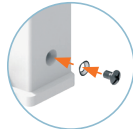

cURus
 Type 12 / Type 4/4X only with CKR 65 (D)
 pending

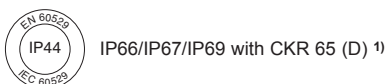

MKG standard insulating version with glued gasket DESINA® ▲

inserts	page:
CJ KM	503
CJK 8MT	506
CJK 8IMT	506
CJK 8M	126 ***
CLK 04 SC	509
CX 1/2 BD	512
CXL 2/4 SF/SM	524
CXL SF/SM	524
CXL 2/4 PF/PM	525
CXL 2/4 PFH/PMH	525
CXL PF/PM	525

*** refer to 2019 Multipole connectors pages
 refer to CN.16 pages

hood



FROM APRIL 2019

hood



FROM APRIL 2019

description

part No.
(entry M25)

part No.
(entry M25)

with pegs, top entry

MKG V25 (light grey RAL 7035)

with pegs, top entry

MKG VN25 (black)

▲ suitable for DESINA® CXL inserts and male inserts without gasket

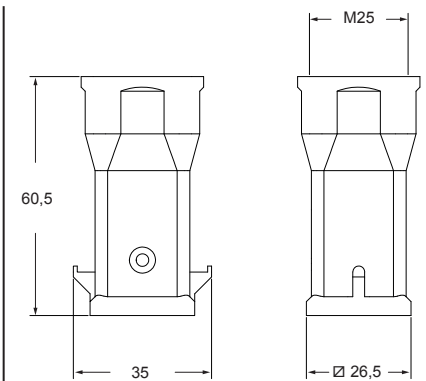
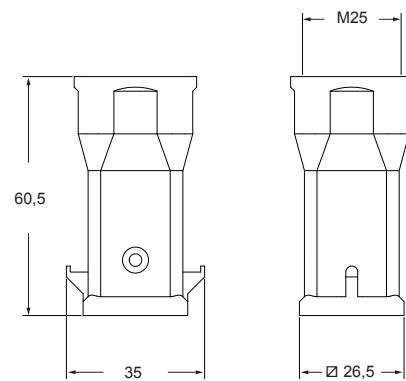

cURus
 Type 12 / Type 4/4X pending



MK standard insulating version

inserts

CK	3 and 4 poles + ⊕
CKS	3 and 4 poles + ⊕
CKSH	3 and 4 poles + ⊕
CD	7 poles + ⊕
CD	8 poles
CQ4	2 poles + ⊕
CQ4	3 poles + ⊕
CQ	5 poles + ⊕
CQ	7 poles + ⊕
CQ	12 poles + ⊕
CQ	21 poles + ⊕

page:

48
49
7 **
53
54
32 ***
23 *
166
8 **
165
11 **

hood

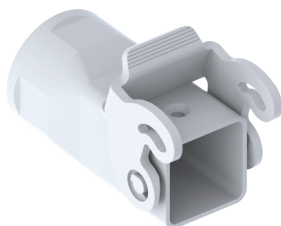

* refer to NEWS 2016 pages
 ** refer to NEWS 2017 pages
 *** refer to 2019 Multipole connectors pages
 ■ refer to CN.16 pages

FROM APRIL 2019

description

part No.
(entry M25)

with lever, top entry **MK VG25** (light grey RAL 7035)

gasket and screw kit for IP66/IP67/IP69 1) **CKR 65**

gasket and screw kit for IP66/IP67/IP69 1) specific for CD 08 inserts **CKR 65 D**

1) To obtain the IP66/IP67/IP69 degree of protection, a kit with insert fixing screw and gasket can be purchased separately.
 Several inserts size "21.21" are already supplied with fixing screw and gasket, which ensures IP66/IP67/IP69 degree of protection. See list below, not including any special version:
 - CQF/M 07, CQF/M 12
 - CJ KF/M
 - CJK 8FT /8IFT /8MT /8IMT, CJK 8M
 - CUK 2FT /3FT
 - CX 1/2 BDF/M
 - CLK 04 SCF /SCF-H /SCM
 - CXL 2/4 PF /PM /PFH /PMH /SF /SM, CXL SF/M

NOTE: Housing type and colour may vary upon specific part No.

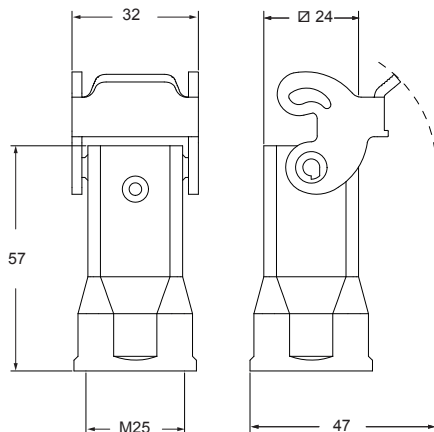
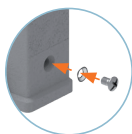

cURus
 Type 12 / Type 4/4X only with CKR 65 (D)
 pending

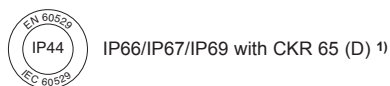

MK standard insulating version

inserts		page:
CK	3 and 4 poles + ⊕	48
CKS	3 and 4 poles + ⊕	49
CKSH	3 and 4 poles + ⊕	7 **
CD	7 poles + ⊕	53
CD	8 poles	54
CQ4	2 poles + ⊕	32 ***
CQ4	3 poles + ⊕	23 *
CQ	5 poles + ⊕	166
CQ	7 poles + ⊕	8 **
CQ	12 poles + ⊕	165
CQ	21 poles + ⊕	11 **

hood

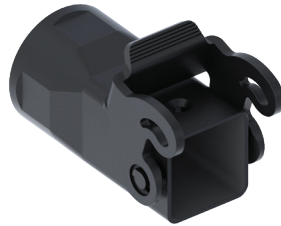

* refer to NEWS 2016 pages
 ** refer to NEWS 2017 pages
 *** refer to 2019 Multipole connectors pages
 ■ refer to CN.16 pages

FROM APRIL 2019

description	part No. (entry M25)
with lever, top entry	MK VGN25 (black)
gasket and screw kit for IP66/IP67/IP69 1)	CKR 65
gasket and screw kit for IP66/IP67/IP69 1) specific for CD 08 inserts	CKR 65 D

1) To obtain the IP66/IP67/IP69 degree of protection, a kit with insert fixing screw and gasket can be purchased separately.
 Several inserts size "21.21" are already supplied with fixing screw and gasket, which ensures IP66/IP67/IP69 degree of protection. See list below, not including any special version:

- CQF/M 07, CQF/M 12
- CJ KF/M
- CJK 8FT /8IFT /8MT /8IMT, CJK 8M
- CUK 2FT /3FT
- CX 1/2 BDF/M
- CLK 04 SCF /SCF-H /SCM
- CXL 2/4 PF /PM /PFH /PMH /SF /SM, CXL SF/M

NOTE: Housing type and colour may vary upon specific part No.

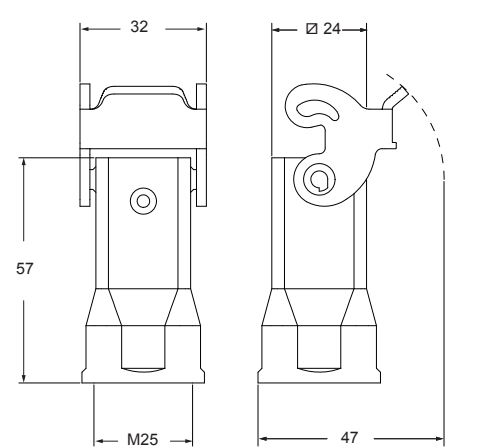
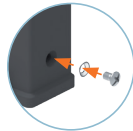

cURus
 Type 12 / Type 4/4X only with CKR 65 (D)
 pending

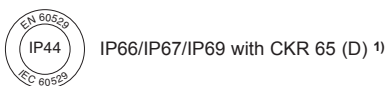

METAL HOODS WITH M25 CABLE ENTRY AND LOCKING LEVER



MKA VG25
metal (zinc alloy) hoods
with locking lever
and M25 cable entry



Find more
information on
our products at
www.ilme.com

TECHNICAL FEATURES

MKA VG25 size “21.21”

- **metal** (zinc alloy) **hoods with locking lever** and M25 cable entry, for all connector inserts size “21.21”;
 - suitable for realizing **free cable-to-cable joints**, ideally in combination with corresponding **MKA V25** metal hood with pegs with M25 cable entry (declined to the corresponding variant, see following paragraphs);
 - suitable for the **wiring with cables with large diameter** (high conductor cross-sectional areas e.g. in combination with CQ4 40A inserts, or large number of individual conductors e.g. in combination with CQ 21 inserts);
 - full compatibility with all range of existing “21.21” hoods and housings;
- available in several variants that differs by:
 - locking lever material: *galvanized steel* (RoHS 2 conform electroplating), or *stainless steel*;
 - locking lever stiffness: *resilient*, “Class type with rolls”, preferable for frequent disconnection and moderate load from the cable, or *rigid*, for higher mechanical load from the cable and less frequent operations;
 - corrosion resistance: **standard** or “**W-Type**” for aggressive environments;
 - EMC shielding: S-Type with conductive surface, to be combined with use of EMC cable gland.

suitable for
realizing free
cable-to-cable
joints

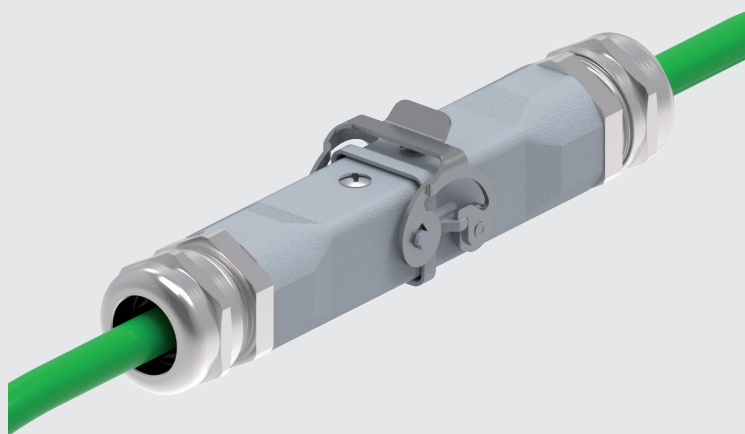

MKAX standard metallic version

inserts	page:
CK	3 and 4 poles + ⊕ 48
CKS	3 and 4 poles + ⊕ 49
CKSH	3 and 4 poles + ⊕ 7 **
CD	8 poles 54
CQ4	2 poles + ⊕ 32 ***
CQ4	3 poles + ⊕ 23 *
CQ	5 poles + ⊕ 166
CQ	7 poles + ⊕ 8 **
CQ	12 poles + ⊕ 165 **
CQ	21 poles + ⊕ 11 **
CJ KM	503
CJK 8MT	506
CJK 8IMT	506
CLK 04 SC	509
CX 1/2 BD	512
CXL 2/4 SF/SM	524
CXL SF/SM	524
CXL 2/4 PF/PM	525
CXL 2/4 PFH/PMH	525
CXL PF/PM	525

* refer to NEWS 2016 pages
 ** refer to NEWS 2017 pages
 *** refer to 2019 Multipole connectors pages
 ■ refer to CN.16 pages

hoods

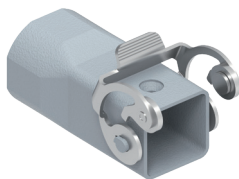

 **STAINLESS STEEL LEVER**
 **FROM FEBRUARY 2019**

description	part No. (entry M25)
-------------	-------------------------

top entry	MKAX VG25
gasket and screw kit for IP66/IP67/IP69 1)	CKR 65
gasket and screw kit for IP66/IP67/IP69 1) specific for CD 08 inserts	CKR 65 D

1) To obtain the IP66/IP67/IP69 degree of protection, a kit with insert fixing screw and gasket can be purchased separately.
 Several inserts size "21.21" are already supplied with fixing screw and gasket, which ensures IP66/IP67/IP69 degree of protection. See list below, not including any special version:

- CQF/M 07, CQF/M 12
- CJ KF/M
- CJK 8FT /8IFT /8MT /8IMT, CJK 8M
- CUK 2FT /3FT
- CX 1/2 BDF/M
- CLK 04 SCF /SCF-H /SCM
- CXL 2/4 PF /PM /PFH /PMH /SF /SM, CXL SF/M

 NOTE: Housing type and colour may vary upon specific part No.

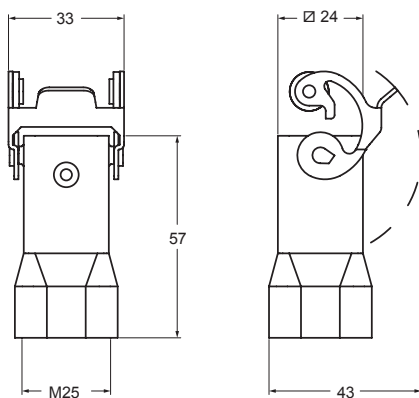
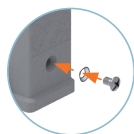

cURus
 Type 12 / Type 4/4X only with CKR 65 (D)
 pending



IP66/IP67/IP69 with CKR 65 (D) 1)

MKA - MKAXX standard metallic version

inserts

CK	3 and 4 poles + ⊕
CKS	3 and 4 poles + ⊕
CKSH	3 and 4 poles + ⊕
CD	8 poles
CQ4	2 poles + ⊕
CQ4	3 poles + ⊕
CQ	5 poles + ⊕
CQ	7 poles + ⊕
CQ	12 poles + ⊕
CQ	21 poles + ⊕
CJ KM	
CJK 8MT	
CJK 8IMT	
CLK 04 SC	
CX 1/2 BD	
CXL 2/4 SF/SM	
CXL SF/SM	
CXL 2/4 PF/PM	
CXL 2/4 PFH/PMH	
CXL PF/PM	

page:

48
49
7 **
54
32 ***
23 *
166
8 **
165
11 **
503
506
506
509
512
524
524
525
525
525

* refer to NEWS 2016 pages
 ** refer to NEWS 2017 pages
 *** refer to 2019 Multipole connectors pages
 ■ refer to CN.16 pages

hoods

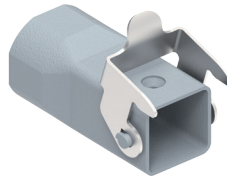

GALVANIZED STEEL RIGID LEVER
FROM FEBRUARY 2019

hoods

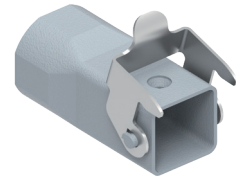

STAINLESS STEEL RIGID LEVER
FROM FEBRUARY 2019

description	part No. (entry M25)	part No. (entry M25)
top entry	MKA VG25	
top entry		MKAXX VG25
gasket and screw kit for IP66/IP67/IP69 1)	CKR 65	CKR 65
gasket and screw kit for IP66/IP67/IP69 1) specific for CD 08 inserts	CKR 65 D	CKR 65 D

1) To obtain the IP66/IP67/IP69 degree of protection, a kit with insert fixing screw and gasket can be purchased separately. Several inserts size "21.21" are already supplied with fixing screw and gasket, which ensures IP66/IP67/IP69 degree of protection. See list below, not including any special version:

- CQF/M 07, CQF/M 12
- CJ KF/M
- CJK 8FT /8IFT /8MT /8IMT, CJK 8M
- CUK 2FT /3FT
- CX 1/2 BDF/M
- CLK 04 SCF /SCF-H /SCM
- CXL 2/4 PF /PM /PFH /PMH /SF /SM, CXL SF/M

NOTE: Housing type and colour may vary upon specific part No.

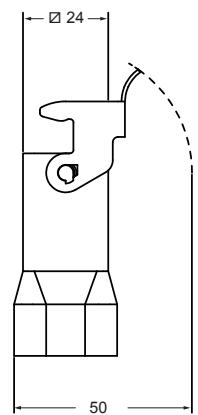
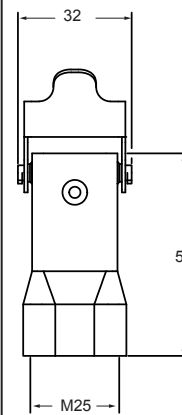
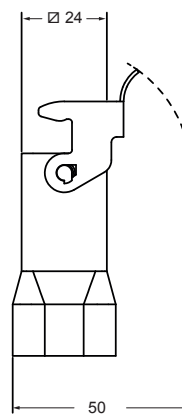
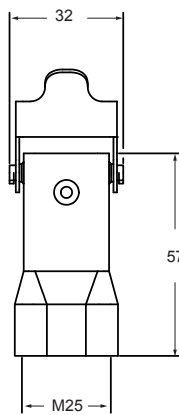
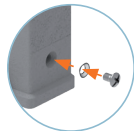

cURus
 Type 12 / Type 4/4X only with CKR 65 (D)
 pending

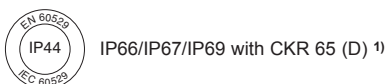

MKAXW for aggressive environments

inserts

CK	3 and 4 poles + ⊕	48
CKS	3 and 4 poles + ⊕	49
CKSH	3 and 4 poles + ⊕	7 **
CD	8 poles	54
CQ4	2 poles + ⊕	32 ***
CQ4	3 poles + ⊕	23 *
CQ	5 poles + ⊕	166
CQ	7 poles + ⊕	8 **
CQ	12 poles + ⊕	165 **
CQ	21 poles + ⊕	11 **
CJ KM		503
CJK 8MT		506
CJK 8IMT		506
CLK 04 SC		509
CX 1/2 BD		512
CXL 2/4 SF/SM		524
CXL SF/SM		524
CXL 2/4 PF/PM		525
CXL 2/4 PFH/PMH		525
CXL PF/PM		525

page:

hoods

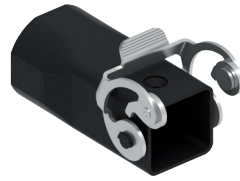

 **STAINLESS STEEL LEVER**

 **FROM FEBRUARY 2019**

* refer to NEWS 2016 pages
 ** refer to NEWS 2017 pages
 *** refer to 2019 Multipole connectors pages
 refer to CN.16 pages

description

part No.
(entry M25)

top entry

MKAXW VG25

gasket and screw kit
for IP66/IP67/IP69 1)

CKR 65

gasket and screw kit for IP66/IP67/IP69 1)
specific for CD 08 inserts

CKR 65 D

1) To obtain the IP66/IP67/IP69 degree of protection, a kit with insert fixing screw and gasket can be purchased separately.

Several inserts size "21.21" are already supplied with fixing screw and gasket, which ensures IP66/IP67/IP69 degree of protection. See list below, not including any special version:

- CQF/M 07, CQF/M 12
- CJ KF/M
- CJK 8FT /8IFT /8MT /8IMT, CJK 8M
- CUK 2FT /3FT
- CX 1/2 BDF/M
- CLK 04 SCF /SCF-H /SCM
- CXL 2/4 PF /PM /PFH /PMH /SF /SM, CXL SF/M

 **NOTE:** Housing type and colour may vary upon specific part No.

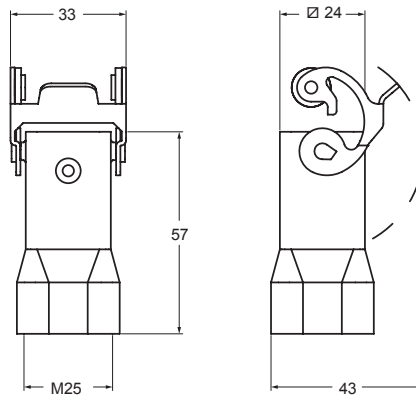
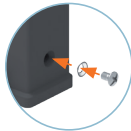

cURus
Type 12 / Type 4/4X only with CKR 65 (D)
pending



IP44 IP66/IP67/IP69 with CKR 65 (D) 1)

MKAXXW for aggressive environments

inserts	page:
CK	3 and 4 poles + ⊕ 48
CKS	3 and 4 poles + ⊕ 49
CKSH	3 and 4 poles + ⊕ 7 **
CD	8 poles 54
CQ4	2 poles + ⊕ 32 ***
CQ4	3 poles + ⊕ 23 *
CQ	5 poles + ⊕ 166
CQ	7 poles + ⊕ 8 **
CQ	12 poles + ⊕ 165 **
CQ	21 poles + ⊕ 11 **
CJ KM	503
CJK 8MT	506
CJK 8IMT	506
CLK 04 SC	509
CX 1/2 BD	512
CXL 2/4 SF/SM	524
CXL SF/SM	524
CXL 2/4 PF/PM	525
CXL 2/4 PFH/PMH	525
CXL PF/PM	525

* refer to NEWS 2016 pages
 ** refer to NEWS 2017 pages
 *** refer to 2019 Multipole connectors pages
 ■ refer to CN.16 pages

hoods

GALVANIZED STEEL RIGID LEVER
FROM FEBRUARY 2019

description	part No. (entry M25)
top entry	MKAXXW VG25
gasket and screw kit for IP66/IP67/IP69 1)	CKR 65
gasket and screw kit for IP66/IP67/IP69 1) specific for CD 08 inserts	CKR 65 D

1) To obtain the IP66/IP67/IP69 degree of protection, a kit with insert fixing screw and gasket can be purchased separately.
 Several inserts size "21.21" are already supplied with fixing screw and gasket, which ensures IP66/IP67/IP69 degree of protection. See list below, not including any special version:

- CQF/M 07, CQF/M 12
- CJ KF/M
- CJK 8FT /8IFT /8MT /8IMT, CJK 8M
- CUK 2FT /3FT
- CX 1/2 BDF/M
- CLK 04 SCF /SCF-H /SCM
- CXL 2/4 PF /PM /PFH /PMH /SF /SM, CXL SF/M

NOTE: Housing type and colour may vary upon specific part No.

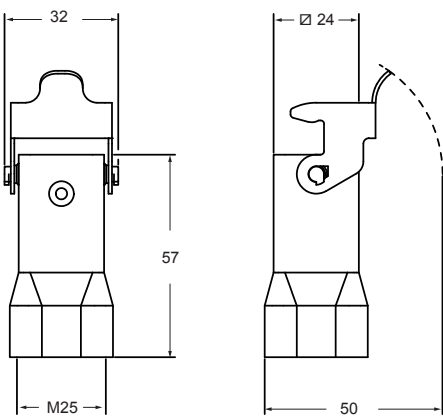
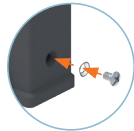

cURus
 Type 12 / Type 4/4X only with CKR 65 (D)
 pending

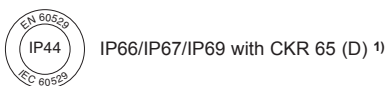

MKAXS EMC version for electromagnetic compatibility

inserts

CK	3 and 4 poles + ⊕	48
CKS	3 and 4 poles + ⊕	49
CKSH	3 and 4 poles + ⊕	7 **
CD	8 poles	54
CQ4	2 poles + ⊕	32 ***
CQ4	3 poles + ⊕	23 *
CQ	5 poles + ⊕	166
CQ	7 poles + ⊕	8 **
CQ	12 poles + ⊕	165 **
CQ	21 poles + ⊕	11 **
CJ KM		503
CJK 8MT		506
CJK 8IMT		506
CLK 04 SC		509
CX 1/2 BD		512
CXL 2/4 SF/SM		524
CXL SF/SM		524
CXL 2/4 PF/PM		525
CXL 2/4 PFH/PMH		525
CXL PF/PM		525

page:

hoods

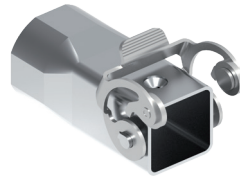

STAINLESS STEEL LEVER

FROM FEBRUARY 2019

* refer to NEWS 2016 pages
 ** refer to NEWS 2017 pages
 *** refer to 2019 Multipole connectors pages
 refer to CN.16 pages

description	part No. (entry M25)
-------------	-------------------------

top entry	MKAXS VG25
gasket and screw kit for IP66/IP67/IP69 1)	CKR 65
gasket and screw kit for IP66/IP67/IP69 1) specific for CD 08 inserts	CKR 65 D

1) To obtain the IP66/IP67/IP69 degree of protection, a kit with insert fixing screw and gasket can be purchased separately.
 Several inserts size "21.21" are already supplied with fixing screw and gasket, which ensures IP66/IP67/IP69 degree of protection. See list below, not including any special version:

- CQF/M 07, CQF/M 12
- CJ KF/M
- CJK 8FT /8IFT /8MT /8IMT, CJK 8M
- CUK 2FT /3FT
- CX 1/2 BDF/M
- CLK 04 SCF /SCF-H /SCM
- CXL 2/4 PF /PM /PFH /PMH /SF /SM, CXL SF/M

NOTE: Housing type and colour may vary upon specific part No.

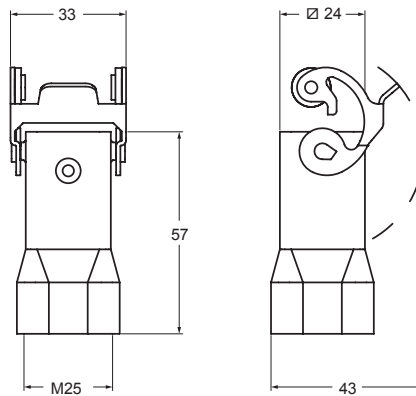
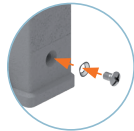

cURus
 Type 12 / Type 4/4X only with CKR 65 (D)
 pending



IP66/IP67/IP69 with CKR 65 (D) 1)

MKAS - MKAXXS EMC version for electromagnetic compatibility

inserts		page:
CK	3 and 4 poles + ⊕	48
CKS	3 and 4 poles + ⊕	49
CKSH	3 and 4 poles + ⊕	7 **
CD	8 poles	54
CQ4	2 poles + ⊕	32 ***
CQ4	3 poles + ⊕	23 *
CQ	5 poles + ⊕	166
CQ	7 poles + ⊕	8 **
CQ	12 poles + ⊕	165
CQ	21 poles + ⊕	11 **
CJ KM		503
CJK 8MT		506
CJK 8IMT		506
CLK 04 SC		509
CX 1/2 BD		512
CXL 2/4 SF/SM		524
CXL SF/SM		524
CXL 2/4 PF/PM		525
CXL 2/4 PFH/PMH		525
CXL PF/PM		525

* refer to NEWS 2016 pages
 ** refer to NEWS 2017 pages
 *** refer to 2019 Multipole connectors pages
 ■ refer to CN.16 pages

hoods

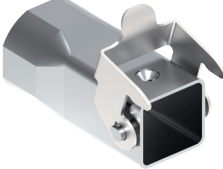

GALVANIZED STEEL RIGID LEVER
FROM FEBRUARY 2019

hoods



STAINLESS STEEL RIGID LEVER
FROM FEBRUARY 2019

description	part No. (entry M25)	part No. (entry M25)
top entry	MKAS VG25	
top entry		MKAXXS VG25
gasket and screw kit for IP66/IP67/IP69 1)	CKR 65	CKR 65
gasket and screw kit for IP66/IP67/IP69 1) specific for CD 08 inserts	CKR 65 D	CKR 65 D

1) To obtain the IP66/IP67/IP69 degree of protection, a kit with insert fixing screw and gasket can be purchased separately.
 Several inserts size "21.21" are already supplied with fixing screw and gasket, which ensures IP66/IP67/IP69 degree of protection. See list below, not including any special version:

- CQF/M 07, CQF/M 12
- CJ KF/M
- CJK 8FT /8IFT /8MT /8IMT, CJK 8M
- CUK 2FT /3FT
- CX 1/2 BDF/M
- CLK 04 SCF /SCF-H /SCM
- CXL 2/4 PF /PM /PFH /PMH /SF /SM, CXL SF/M

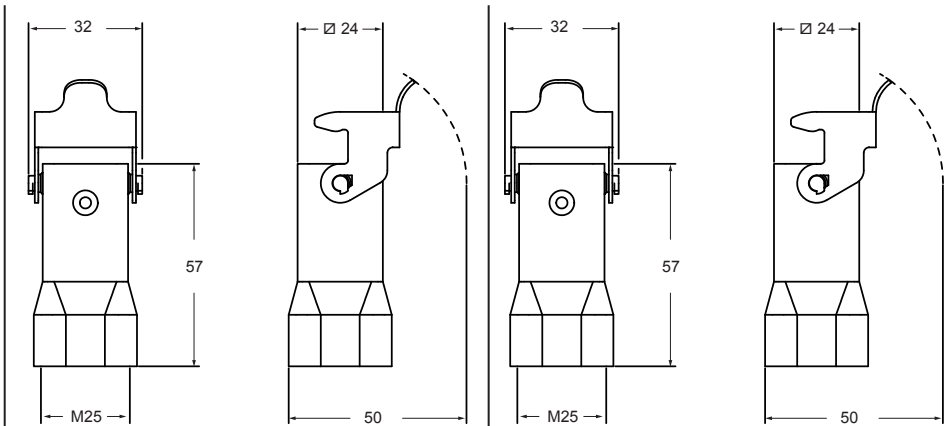
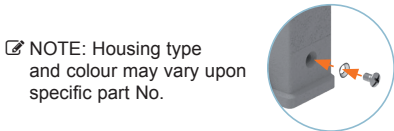

cURus
 Type 12 / Type 4/4X only with CKR 65 (D)
 pending

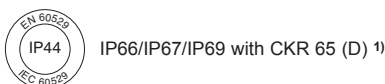

METAL HOODS M25

MGK V25, MGK V25 B – IP68 HIGH PROTECTION



MGK V25 - MGK V25 B
size "21.21", metal hoods (zinc alloy)
with two-point screw locking
or bayonet locking
and M25 cable entry



Find more
information on
our products at
www.ilme.com

TECHNICAL FEATURES

MGK V25, MGK V25 B

- metal hoods (zinc alloy) size "21.21" with two-point **screw locking** or **bayonet locking** and **M25 cable entry**, degree of protection IP66/IP68/IP69;
- suitable for all inserts size "21.21";
- suitable for the **wiring with cables with large diameter** (high conductor cross-sectional areas e.g. in combination with CQ4 40A inserts, or large number of individual conductors e.g. in combination with CQ 21 inserts);
- full compatibility with all the existing range of IP66/**IP68**/IP69 **CGK/MGK** "21.21" connector enclosures and covers;
- **inherent EMC shielding** with conductive surface, to be combined with use of EMC cable gland;
- dust protection cover **CGKCP MB** available (for more information please refer to page 497 CN.16 catalogue).



suitable for
the wiring
with large
diameter
cables



MGK high protection IP68 version (screw locking)

inserts

CK	3 poles + ⊕	48
CK	4 poles + ⊕	48
CKS	3 poles + ⊕	49
CKS	4 poles + ⊕	49
CKSH	3 poles + ⊕	7 **
CKSH	4 poles + ⊕	7 **
CD 1)	8 poles	54
CQ4	2 poles + ⊕	32 ***
CQ4	3 poles + ⊕	23 *
CQ	5 poles + ⊕	166
CQ	7 poles + ⊕	8 **
CQ	12 poles + ⊕	165
CQ	21 poles + ⊕	11 **
CJ KM		503
CJK 8MT		506
CJK 8IMT		506
CLK 04 SC		509
CX 1/2 BD		512

page:

hoods



FROM APRIL 2019

* refer to NEWS 2016 pages
 ** refer to NEWS 2017 pages
 *** refer to 2019 Multipole connectors pages
 refer to CN.16 pages

description	part No. (entry M25)
-------------	-------------------------

top entry	MGK V25
-----------	----------------

- Eliminate the gasket and the fixing screw; provided with the insert
- To fix the insert, use the screw with gasket provided with the enclosure (except CD 08 see note below).

1) To ensure IP68 degree of protection with CD 08 insert, purchase the kit CKR 65 D.

In this case do not use the screw supplied with the enclosure.

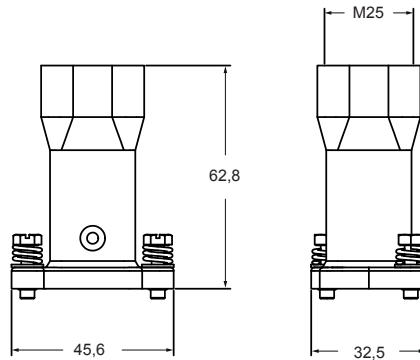

CGKCP MB
 dust protection
 cover



cURus
 Type 12 / Type 4/4X only with CKR 65 (D)
 pending



according to IEC/EN 60529

MGK B high protection IP68 version (bayonet locking)

inserts

CK	3 poles + ⊕	48
CK	4 poles + ⊕	48
CKS	3 poles + ⊕	49
CKS	4 poles + ⊕	49
CKSH	3 poles + ⊕	7 **
CKSH	4 poles + ⊕	7 **
CD 1)	8 poles	54
CQ4	2 poles + ⊕	32 ***
CQ4	3 poles + ⊕	23 *
CQ	5 poles + ⊕	166
CQ	7 poles + ⊕	8 **
CQ	12 poles + ⊕	165
CQ	21 poles + ⊕	11 **
CJ KM		503
CJK 8MT		506
CJK 8IMT		506
CLK 04 SC		509
CX 1/2 BD		512

page:

hoods



* refer to NEWS 2016 pages
 ** refer to NEWS 2017 pages
 *** refer to 2019 Multipole connectors pages
 refer to CN.16 pages

FROM APRIL 2019

description	part No. (entry M25)
-------------	-------------------------

top entry	MGK V25 B
-----------	------------------

- Eliminate the gasket and the fixing screw; provided with the insert
- To fix the insert, use the screw with gasket provided with the enclosure (except CD 08 see note below).

1) To ensure IP68 degree of protection with CD 08 insert, purchase the kit CKR 65 D.

In this case do not use the screw supplied with the enclosure.

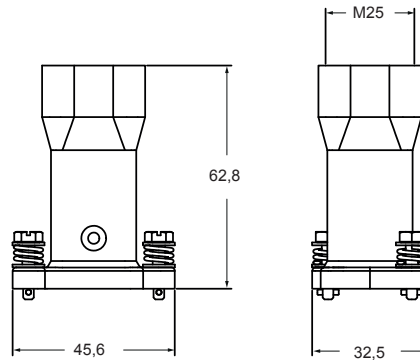

CGKCP MB
 dust protection
 cover



cURus
 Type 12 / Type 4/4X only with CKR 65 (D)
 pending



according to IEC/EN 60529

HOODS WITH PEGS FOR CENTRAL LEVER CAV/MAV GYC, CFV/MFV GYC

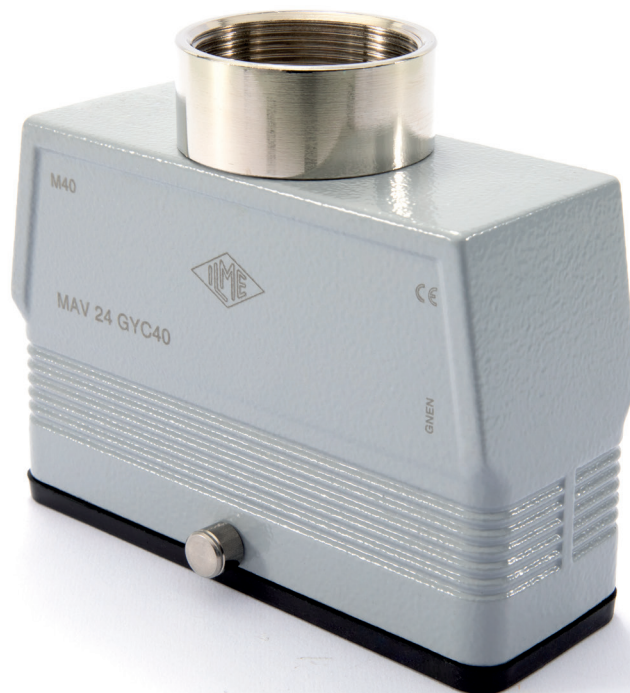

Hoods with pegs
for central lever cable-to-cable connector joints
available in all sizes



Find more
information on
our products at
www.ilme.com

TECHNICAL FEATURES

CAV/MAV GYC, CFV/MFV GYC

- aluminium die cast high construction connector **hoods with pegs** (two, stainless steel, with roller bearing), centrally mounted along the long sides, **and edge sealing gasket**, available in all sizes (“44.27”, “57.27”, “77.27” and “104.27”) with **top cable entry** of various **Pg** thread sizes or **M...** metric sizes;
- intended for realizing a **free cable-to-cable connector joint** in combination with connector inserts (male and female) and correspondingly sized connector **hood with central locking lever**, either top cable entry (CAV/MAV ... YX...), or side cable entry (CAO/MAO ... YX...) with adapter (or with alternative variants without adapter identified by **F** in the pre-code, which are available upon request), or – only for the available sizes “77.27” and “104.27” – with **inclined hood with central locking lever**, either top cable entry (CIV/MIV ... XY...) or side cable entry (CIO/MIO ... XY...);
- intended also for realizing cable-to-panel connection with central lever housings (either bulkhead or surface mounting);
- possibility to secure the locking of a central lever connector coupling size “104.27” by means of the new locking device CR YLK 24/24 SL (see page 113);
- available either:
 - **with adapter (A** in the pre-code, nickel-plated brass or integral with the hood), for use with **semi-gland** (sealing gasket, rings and pressure nut) to be provided separately, or
 - **without adapter (F** in the pre-code) with through-thread cable entry, for use with a **complete cable gland** or conduit fitting of suitable size, to be provided separately;
- available only in standard version.
NOTE: For feasibility of variants, please contact ILME offices.

**free cable-to-cable
connector joint in
combination with
connector inserts**

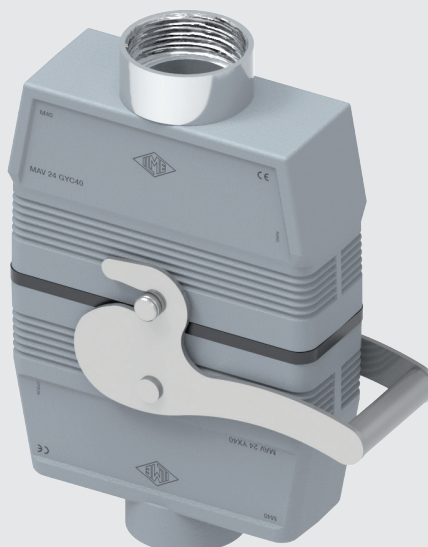

CA - MA and CF - MF central lever

inserts

CDD	24 poles + ⊕	67
CDS	9 poles + ⊕	78
CDSH	9 poles + ⊕	9 *
CDSH NC	6 poles + ⊕	19 *
CSH	6 poles + ⊕	91
CSE	6 poles + ⊕	104
CNE	6 poles + ⊕	104
CCE	6 poles + ⊕	110
CSS	6 poles + ⊕	122
CQE	10 poles + ⊕	138
MIXO	2 modules	179 - 215

page:

hoods for central lever



hoods for central lever



* refer to NEWS 2016 pages
 refer to CN.16 pages

FROM MARCH 2019

FROM MARCH 2019

description	part No.	entry Pg	part No.	entry M	part No.	entry Pg	part No.	entry M
with pegs, top entry, high construction	CAV 06 GYC21	21	MAV 06 GYC25	25				
with pegs, top entry, high construction	CAV 06 GYC29	29	MAV 06 GYC32	32				
with pegs, top entry, high construction			MAV 06 GYC40	40				
with pegs, top entry, high construction, without adapter *					CFV 06 GYC21	21	MFV 06 GYC25	25
with pegs, top entry, high construction, without adapter *					CFV 06 GYC29	29	MFV 06 GYC32	32
with pegs, top entry, high construction, without adapter *							MFV 06 GYC40	40

* enclosure without adapter, threaded on the body, to be used only with a complete cable gland.

Even when coding is not required, it is recommended to use CRM and CRF pins with CD and CDD inserts and CRM CX and CRF CX pins with MIXO inserts to reduce movements when fitting and removing the connectors and to avoid contact damages.

Within this scope, the EN 175301-801 standard (former DIN 43 652) requires a maximum angular fluctuation of $\pm 5^\circ$ on the long side, $\pm 2^\circ$ on the short side.

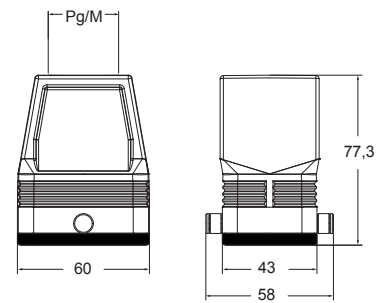
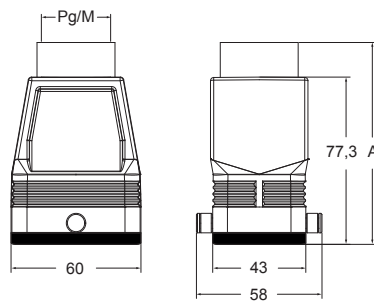

part No.	A
CAV 06 GYC21	92,3
CAV 06 GYC29	93,8
MAV 06 GYC25	92,3
MAV 06 GYC32	93,3
MAV 06 GYC40	96,3

cURus
 Type 12 / Type 4/4X
 pending



CA - MA and CF - MF central lever

inserts

CDD	42 poles + ⊕	69
CDS	18 poles + ⊕	79
CDSH	18 poles + ⊕	10 *
CSH	10 poles + ⊕	92
CSE	10 poles + ⊕	105
CNE	10 poles + ⊕	105
CCE	10 poles + ⊕	111
CSS	10 poles + ⊕	123
CQE	18 poles + ⊕	139
MIXO	3 modules	179 - 215

page:

hoods for central lever



hoods for central lever



* refer to NEWS 2016 pages
 refer to CN.16 pages

FROM MARCH 2019

FROM MARCH 2019

description	part No.	entry Pg	part No.	entry M	part No.	entry Pg	part No.	entry M
with pegs, top entry, high construction	CAV 10 GYC21	21	MAV 10 GYC25	25				
with pegs, top entry, high construction	CAV 10 GYC29	29	MAV 10 GYC32	32				
with pegs, top entry, high construction			MAV 10 GYC40	40				
with pegs, top entry, high construction, without adapter *					CFV 10 GYC21	21	MFV 10 GYC25	25
with pegs, top entry, high construction, without adapter *					CFV 10 GYC29	29	MFV 10 GYC32	32
with pegs, top entry, high construction, without adapter *							MFV 10 GYC40	40

* enclosure without adapter, threaded on the body, to be used only with a complete cable gland.

Even when coding is not required, it is recommended to use CRM and CRF pins with CD and CDD inserts and CRM CX and CRF CX pins with MIXO inserts to reduce movements when fitting and removing the connectors and to avoid contact damages.

Within this scope, the EN 175301-801 standard (former DIN 43 652) requires a maximum angular fluctuation of $\pm 5^\circ$ on the long side, $\pm 2^\circ$ on the short side.

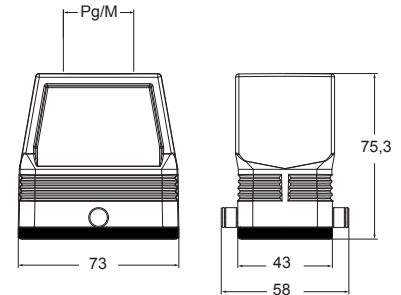
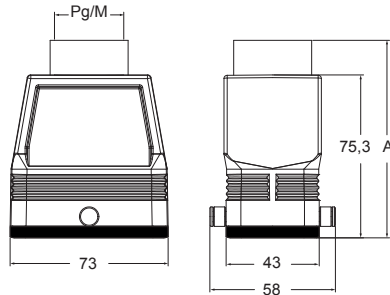

part No.	A
CAV 10 GYC21	90,3
CAV 10 GYC29	91,8
MAV 10 GYC25	90,3
MAV 10 GYC32	91,3
MAV 10 GYC40	94,3

cURus
 Type 12 / Type 4/4X
 pending



CA - MA and CF - MF central lever

inserts

CD	40 poles + ⊕	57
CDD	72 poles + ⊕	70
CDS	27 poles + ⊕	80
CDSH	27 poles + ⊕	11 *
CSH	16 poles + ⊕	93
CSE	16 poles + ⊕	106
CNE	16 poles + ⊕	106
CCE	16 poles + ⊕	112
CSS	16 poles + ⊕	124
CQE	32 poles + ⊕	140
CQEE	40 poles + ⊕	146
MIXO	4 modules	179 - 215

page:

hoods for central lever



hoods for central lever



* refer to NEWS 2016 pages
 refer to CN.16 pages

FROM MARCH 2019

FROM MARCH 2019

description	part No.	entry Pg	part No.	entry M	part No.	entry Pg	part No.	entry M
with pegs, top entry, high construction	CAV 16 GYC21	21	MAV 16 GYC25	25				
with pegs, top entry, high construction	CAV 16 GYC29	29	MAV 16 GYC32	32				
with pegs, top entry, high construction			MAV 16 GYC40	40				
with pegs, top entry, high construction, without adapter *					CFV 16 GYC21	21	MFV 16 GYC25	25
with pegs, top entry, high construction, without adapter *					CFV 16 GYC29	29	MFV 16 GYC32	32
with pegs, top entry, high construction, without adapter *							MFV 16 GYC40	40

* enclosure without adapter, threaded on the body, to be used only with a complete cable gland.

Even when coding is not required, it is recommended to use CRM and CRF pins with CD and CDD inserts and CRM CX and CRF CX pins with MIXO inserts to reduce movements when fitting and removing the connectors and to avoid contact damages.

Within this scope, the EN 175301-801 standard (former DIN 43 652) requires a maximum angular fluctuation of $\pm 5^\circ$ on the long side, $\pm 2^\circ$ on the short side.

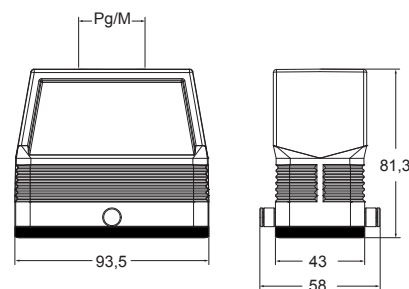
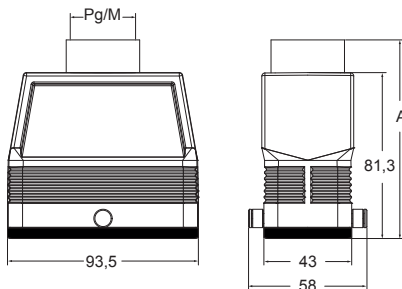

part No.	A
CAV 16 GYC21	96,3
CAV 16 GYC29	97,8
MAV 16 GYC25	96,3
MAV 16 GYC32	97,6
MAV 16 GYC40	100,3

cURus
 Type 12 / Type 4/4X
 pending



CA - MA and CF - MF central lever

inserts

CD	64 poles + ⊕	59
CDD	108 poles + ⊕	72
CDS	42 poles + ⊕	81
CDSH	42 poles + ⊕	12 *
CSH	24 poles + ⊕	94
CSE	24 poles + ⊕	107
CNE	24 poles + ⊕	107
CCE	24 poles + ⊕	113
CSS	24 poles + ⊕	125
CQE	46 poles + ⊕	141
CQEE	64 poles + ⊕	147
MIXO	6 modules	179 - 215

page:

hoods for central lever



hoods for central lever



* refer to NEWS 2016 pages
refer to CN.16 pages

FROM MARCH 2019

FROM MARCH 2019

description	part No.	entry Pg	part No.	entry M	part No.	entry Pg	part No.	entry M
with pegs, top entry, high construction	CAV 24 GYC21	21	MAV 24 GYC25	25				
with pegs, top entry, high construction	CAV 24 GYC29	29	MAV 24 GYC32	32				
with pegs, top entry, high construction			MAV 24 GYC40	40				
with pegs, top entry, high construction, without adapter *					CFV 24 GYC21	21	MFV 24 GYC25	25
with pegs, top entry, high construction, without adapter *					CFV 24 GYC29	29	MFV 24 GYC32	32
with pegs, top entry, high construction, without adapter *							MFV 24 GYC40	40

* enclosure without adapter, threaded on the body, to be used only with a complete cable gland.

Even when coding is not required, it is recommended to use CRM and CRF pins with CD and CDD inserts and CRM CX and CRF CX pins with MIXO inserts to reduce movements when fitting and removing the connectors and to avoid contact damages.

Within this scope, the EN 175301-801 standard (former DIN 43 652) requires a maximum angular fluctuation of ±5° on the long side, ±2° on the short side.

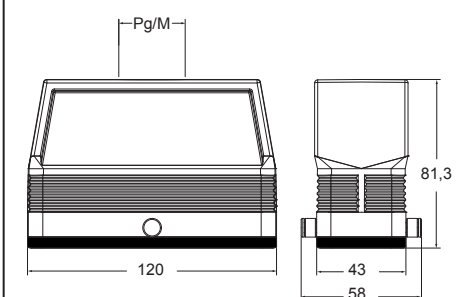
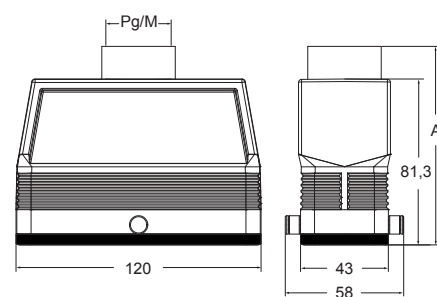

part No.	A
CAV 24 GYC21	96,3
CAV 24 GYC29	97,8
MAV 24 GYC25	96,3
MAV 24 GYC32	97,6
MAV 24 GYC40	100,3

cURus
Type 12 / Type 4/4X
pending



SIZE "77.62" HOUSINGS WITH SINGLE STAINLESS STEEL RIGID LEVER



CHIX - CHPX
bulkhead and surface
mounting housings with single
stainless steel rigid lever



Find more
information on
our products at
www.ilme.com

TECHNICAL FEATURES

CHIX - CHPX

- **bulkhead and surface mounting housings with single stainless steel rigid lever;**
- suitable for coupling in combination with hoods with 2 pegs of same size and - as applicable - covers with two pegs, same size (CN.16 pages 269-270);
- best choice in case of **high mechanical load** from the cable or use in combination with a connector coupling employing a high number of pneumatic and/or optical fibre contacts;
- **IP66 degree of protection** for versions without hinged cover, when "mated and locked" with the locking lever to a corresponding hood or to a free cover;
- **IP65 degree of protection** for versions with hinged metal cover when "mated and locked" with the locking lever, either to the cover or to the corresponding hood;
- available upon request in "**W-Type**" version for aggressive environment and in **180 °C** version for high temperatures.

single
stainless
steel rigid
lever

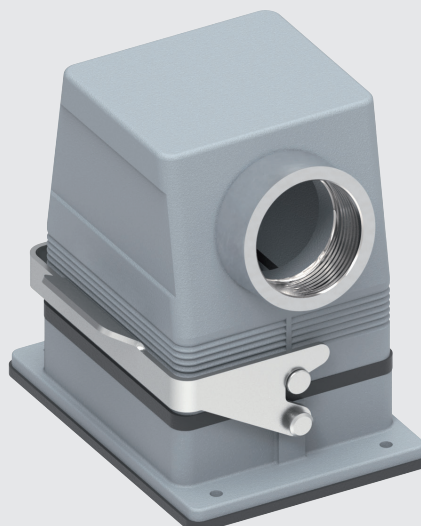

CHIX C-TYPE standard version

inserts		page:
CD	80 poles + ⊕	60
CDD	144 poles + ⊕	73
CDS	54 poles + ⊕	82
CDSH	54 poles + ⊕	13*
CSH	32 poles + ⊕	95
CSE	32 poles + ⊕	108
CNE	32 poles + ⊕	108
CCE	32 poles + ⊕	114
CSS	32 poles + ⊕	126
CTSE (16A) 1)	32 poles + ⊕	134
CQE	64 poles + ⊕	142
CMCE	12+4 (aux) poles + ⊕	154
CME	12+4 (aux) poles + ⊕	155
CMSH	12+4 (aux) poles + ⊕	155
CP	12 poles + ⊕	163
MIXO	4 + 4 modules	179 - 215

insert dimensions:
2 x (77,5 x 27) mm

* refer to NEWS 2016 pages
refer to CN.16 pages

bulkhead mounting housings with single lever

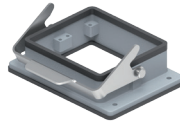

FROM MARCH 2019

bulkhead mounting housings with single lever, with cover



FROM MARCH 2019

description

part No.

part No.

with lever

CHIX 32 L

with lever and aluminum cover

CHIX 32 LS

with lever and plastic cover

CHIX 32 LP

The enclosures ensure IP66 degree of protection (or IP65 for cover versions) rating when mated and locked with the closing levers.

1) can be used only in bulkhead mounting housings

CHIX L

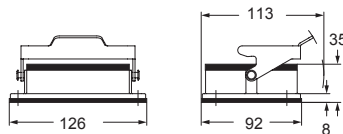

panel cut-out for enclosures

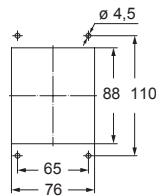

CHIX LS and CHIX LP

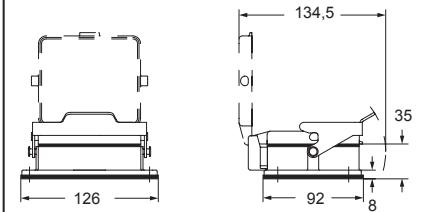

panel cut-out for enclosures

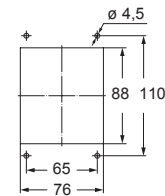

cURus
Type 12 / Type 4/4X
(except enclosures with plastic cover)
pending



CHPX C-TYPE standard version

inserts

CD	80 poles + ⊕	60
CDD	144 poles + ⊕	73
CDS	54 poles + ⊕	82
CDSH	54 poles + ⊕	13 *
CSH	32 poles + ⊕	95
CSE	32 poles + ⊕	108
CNE	32 poles + ⊕	108
CCE	32 poles + ⊕	114
CSS	32 poles + ⊕	126
CTSE (16A) ¹⁾	32 poles + ⊕	134
CQE	64 poles + ⊕	142
CMCE	12+4 (aux) poles + ⊕	154
CME	12+4 (aux) poles + ⊕	155
CMSH	12+4 (aux) poles + ⊕	155
CP	12 poles + ⊕	163
MIXO	4 + 4 modules	179 - 215

page:

surface mounting housings with single lever



FROM MARCH 2019

surface mounting housings with single lever, with cover

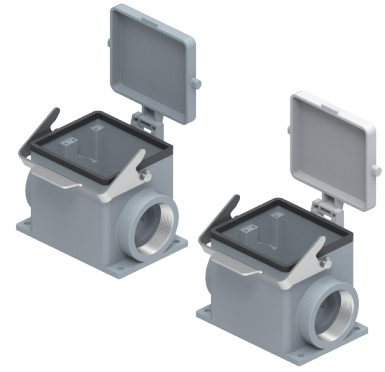

FROM MARCH 2019

insert dimensions:
2 x (77,5 x 27) mm

* refer to NEWS 2016 pages

refer to CN.16 pages

description	part No.	entry Pg	part No.	entry M	part No.	entry Pg	part No.	entry M
with lever	CHPX 32 L29	29						
with lever	CHPX 32 L	36	MHPX 32 L40	40				
with lever and aluminum cover					CHPX 32 LS29	29		
with lever and aluminum cover					CHPX 32 LS	36	MHPX 32 LS40	40
with lever and plastic cover					CHPX 32 LP29	29		
with lever and plastic cover					CHPX 32 LP	36	MHPX 32 LP40	40
with lever and plastic cover							MHPX 32 LP50	50

The enclosures ensure IP66 degree of protection (or IP65 for cover versions) rating when mated and locked with the closing levers.

¹⁾ can be used only in bulkhead mounting housings

CHPX L and MHPX L

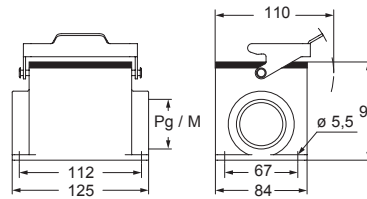

CHPX LS - MHPX LS and CHPX LP - MHPX LP

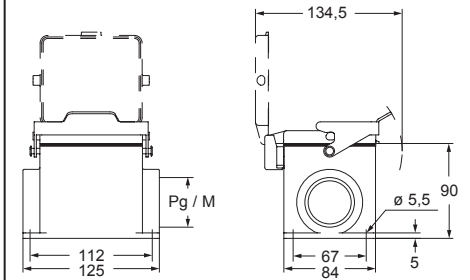

cURus
Type 12 / Type 4/4X
(except enclosures with plastic cover)
pending



SURFACE MOUNTING HOUSINGS WITH SIMPLEX SELF-CLOSING HINGED COVER



CVP/MVP...LSP - CZP/MZP...LSP
surface mounting housings with
SIMPLEX self-closing hinged cover
in self-extinguish thermoplastic
material reinforced with glass fibre



Find more
information on
our products at
www.ilme.com

TECHNICAL FEATURES

CVP/MVP...LSP - CZP/MZP...LSP

- die cast aluminium alloy surface mounting housings with **SIMPLEX self-closing hinged cover in self-extinguish thermoplastic material** reinforced with glass fibre, UL approved;
 - complete the already available range of bulkhead mounting housings equipped with SIMPLEX self-closing hinged cover;
 - **V-Type locking lever** for CVP /MVP or CVAP /MVAP 06 /10 /16 /24 LSP... housings;
 - **IL-BRID locking lever** for CZP /MZP 15 LSP... or CZAP /MZAP 25LSP... housings;
- V-Type locking lever equipped models:
 - **IP44** degree of protection when **not** “mated and locked”,
 - **IP65** degree of protection when “mated and locked” with the closing lever;
 - IL-BRID locking lever equipped models:
 - **IP65** degree of protection when “mated and locked” with the closing lever.

SIMPLEX
self-closing
hinged cover.
V-Type
lever version



CV - CVA and MVP - MVAP V-TYPE lever SIMPLEX self-closing cover

inserts

CDD	24 poles + ⊕	67
CDS	9 poles + ⊕	78
CDSH	9 poles + ⊕	9 *
CDSH NC	6 poles + ⊕	19 *
CSH	6 poles + ⊕	91
CSE	6 poles + ⊕	104
CNE	6 poles + ⊕	104
CCE	6 poles + ⊕	110
CSS	6 poles + ⊕	122
CQE	10 poles + ⊕	138
MIXO	2 modules	179 - 215

page:

surface mounting housings
with stainless steel single lever
and SIMPLEX cover



* refer to NEWS 2016 pages
refer to CN.16 pages

FROM MARCH 2019

description	part No.	entry Pg	part No	entry M
with lever and cover	CVP 06 LSP16	16	MVP 06 LSP20	20
with lever and cover, high construction	CVAP 06LSP21	21	MVAP 06LSP25	25
with lever and cover, high construction	CVAP 06LSP29	29	MVAP 06LSP32	32
with lever and cover, high construction			MVAP 06LSP40	40

The enclosures ensure IP65 degree of protection when mated and locked with the closing lever, or IP44 degree of protection when not mated and locked with lever.

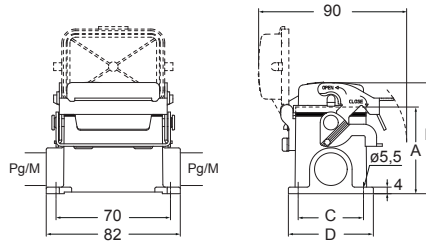

part No.	A	B	C	D
CVP / MVP 6 LSP	53	68	40	52
CVAP / MVAP 6 LSP	74	89	45	57

cURus
Type 12 / Type 4/4X
pending



CV - CVA and MVP - MVAP V-TYPE lever SIMPLEX self-closing cover

inserts

CDD	42 poles + ⊕	69
CDS	18 poles + ⊕	79
CDSH	18 poles + ⊕	10 *
CSH	10 poles + ⊕	92
CSE	10 poles + ⊕	105
CNE	10 poles + ⊕	105
CCE	10 poles + ⊕	111
CSS	10 poles + ⊕	123
CQE	18 poles + ⊕	139
CMCE	3+2 (aux) poles + ⊕	148
CMSH	3+2 (aux) poles + ⊕	149
CX	8/24 poles + ⊕	169
MIXO	3 modules	179 - 215

page:

surface mounting housings with stainless steel single lever and SIMPLEX cover



* refer to NEWS 2016 pages
 refer to CN.16 pages

FROM MARCH 2019

description	part No.	entry Pg	part No	entry M
with lever and cover	CVP 10 LSP16	16	MVP 10 LSP20	20
with lever and cover			MVP 10 LSP25	25
with lever and cover, high construction	CVAP 10LSP21	21	MVAP 10LSP25	25
with lever and cover, high construction	CVAP 10LSP29	29	MVAP 10LSP32	32
with lever and cover, high construction			MVAP 10LSP40	40

The enclosures ensure IP65 degree of protection when mated and locked with the closing lever, or IP44 degree of protection when not mated and locked with lever.

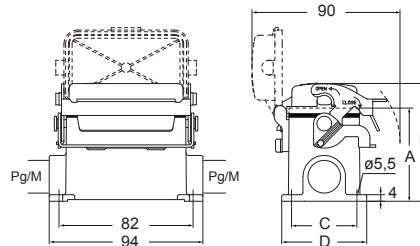

part No.	A	B	C	D
CVP / MVP 10 LSP	57	72	40	52
CVAP / MVAP 10 LSP	74	89	45	57

cURus
 Type 12 / Type 4/4X
 pending



CV - CVA and MVP - MVAP V-TYPE lever SIMPLEX self-closing cover

inserts

CD	40 poles + ⊕	57
CDD	72 poles + ⊕	70
CDS	27 poles + ⊕	80
CDSH	27 poles + ⊕	11 *
CSH	16 poles + ⊕	93
CSE	16 poles + ⊕	106
CNE	16 poles + ⊕	106
CCE	16 poles + ⊕	112
CSS	16 poles + ⊕	124
CQE	32 poles + ⊕	140
CQEE	40 poles + ⊕	146
CMCE, CMSH	6+2 (aux) poles + ⊕	150 - 151
CP	6 poles + ⊕	162
CX	6/36, 6/12 and 12/2 poles + ⊕	170 - 171
CX	4/0 and 4/2 poles + ⊕	172
MIXO	4 modules	179 - 215

page:

surface mounting housings
with stainless steel single lever
and SIMPLEX cover



FROM MARCH 2019

* refer to NEWS 2016 pages
 refer to CN.16 pages

description	part No.	entry Pg	part No	entry M
with lever and cover	CVP 16 LSP21	21	MVP 16 LSP25	25
with lever and cover, high construction	CVAP 16LSP21	21	MVAP 16LSP25	25
with lever and cover, high construction	CVAP 16LSP29	29	MVAP 16LSP32	32
with lever and cover, high construction			MVAP 16LSP40	40

The enclosures ensure IP65 degree of protection when mated and locked with the closing lever, or IP44 degree of protection when not mated and locked with lever.

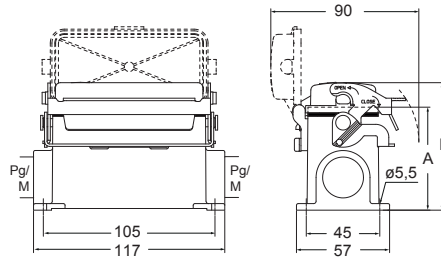

part No.	A	B
CVP / MVP 16 LSP	63	78
CVAP / MVAP 16 LSP	81	96

cURus
Type 12 / Type 4/4X
pending



CV - CVA and MVP - MVAP V-TYPE lever SIMPLEX self-closing cover

inserts		page:
CD	64 poles + ⊕	59
CDD	108 poles + ⊕	72
CDS	42 poles + ⊕	81
CDSH	42 poles + ⊕	12 *
CSH	24 poles + ⊕	94
CSE	24 poles + ⊕	107
CNE	24 poles + ⊕	107
CCE	24 poles + ⊕	113
CSS	24 poles + ⊕	125
CQE	46 poles + ⊕	141
CQEE	64 poles + ⊕	147
CMCE	10+2 (aux) poles + ⊕	152
CMSH	10+2 (aux) poles + ⊕	153
CX	4/8 and 6/6 poles + ⊕	173, 175
MIXO	6 modules	179 - 215

* refer to NEWS 2016 pages
 refer to CN.16 pages

surface mounting housings with stainless steel single lever and SIMPLEX cover



FROM MARCH 2019

description	part No.	entry Pg	part No	entry M
with lever and cover	CVP 24 LSP21	21	MVP 24 LSP25	25
with lever and cover, high construction	CVAP 24LSP21	21	MVAP 24LSP25	25
with lever and cover, high construction	CVAP 24LSP29	29	MVAP 24LSP32	32
with lever and cover, high construction			MVAP 24LSP40	40

The enclosures ensure IP65 degree of protection when mated and locked with the closing lever, or IP44 degree of protection when not mated and locked with lever.

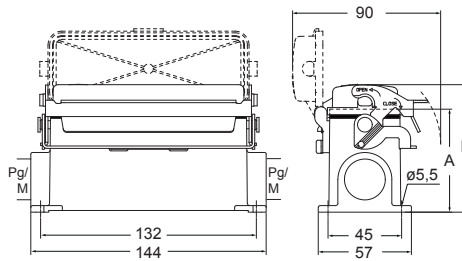

part No.	A	B
CVP / MVP 24 LSP	63	78
CVAP / MVAP 24 LSP	81	96

cURus
 Type 12 / Type 4/4X
 pending



inserts

CD	15 poles + ⊕	55
CSAH	10 poles + ⊕	87
CDA	10 poles + ⊕	98
CDC	10 poles + ⊕	99
MIXO	1 module	179 - 214

page:

surface mounting housings
with single lever and SIMPLEX cover



 FROM MARCH 2019

 refer to CN.16 pages

description	part No.	entry Pg	part No	entry M
with lever and cover	CZP 15 LSP16	16	MZP 15 LSP20	20
with lever and cover	CZP 15 LSP21	21	MZP 15 LSP25	25

 The enclosures ensure IP65 degree of protection when mated and locked with the closing lever.

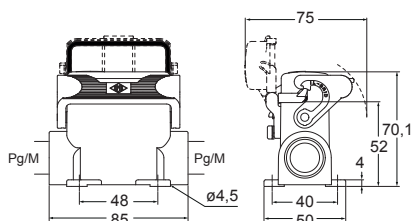

cURus
Type 12 / Type 4/4X
pending



CZA - MZA IL-BRID lever standard version SIMPLEX self-closing cover

inserts

CD	25 poles + ⊕	56
CDD	38 poles + ⊕	68
CSAH	16 poles + ⊕	88
CDA	16 poles + ⊕	100
CDC	16 poles + ⊕	101

page:

surface mounting housings
with single lever and SIMPLEX cover



FROM MARCH 2019

refer to CN.16 pages

description	part No.	entry Pg	part No	entry M
with lever and cover, high construction	CZAP 25LSP16	16	MZAP 25LSP20	20
with lever and cover, high construction	CZAP 25LSP21	21	MZAP 25LSP25	25

The enclosures ensure IP65 degree of protection when mated and locked with the closing lever.

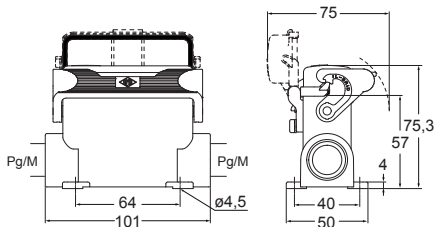

cURus
Type 12 / Type 4/4X
pending



LOCKING DEVICE FOR “CLASS” LOCKING LEVERS CR CLK

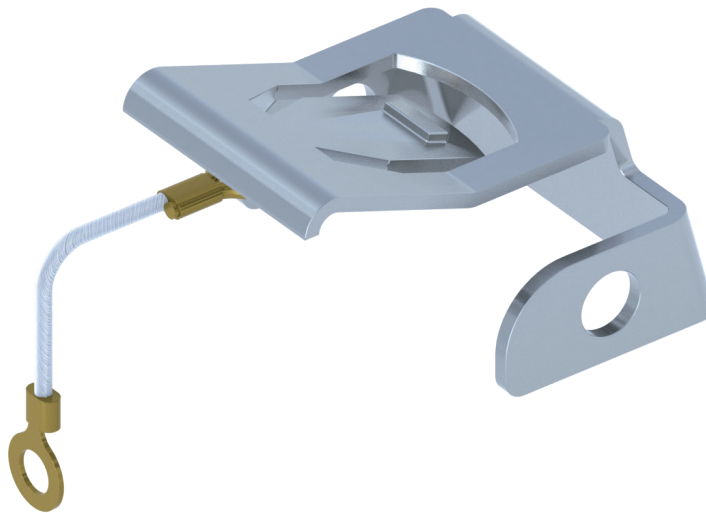

Locking device for bulkhead
and surface mounting housings, low profile,
with two “Class” locking levers



Find more
information on
our products at
www.ilme.com

TECHNICAL FEATURES

CR CLK

- **locking device**, made in **stainless steel**, that can be easily placed on the “Class” locking lever handle of a **two-lever bulkhead mounting housing or a “low profile” surface mounting housing** of sizes “57.27”, “77.27” and “104.27”, in order to avoid unwanted and potentially hazardous accidental opening of the locking lever while the connectors are under working condition;
- **possibility to apply, optionally, a padlock (TM BLC125**, separately available, 5 mm shackle diameter, 40 mm arc clearance) with **anti-tamper function**, i.e. to secure the locking against unauthorized attempts to open the locking lever and disconnect the connector coupling;
- with eyelet cord end, for fastening the locking device to the intended housing when not in use.

Anti-tamper
function by
TM BLC125
padlock
(to be ordered
separately)

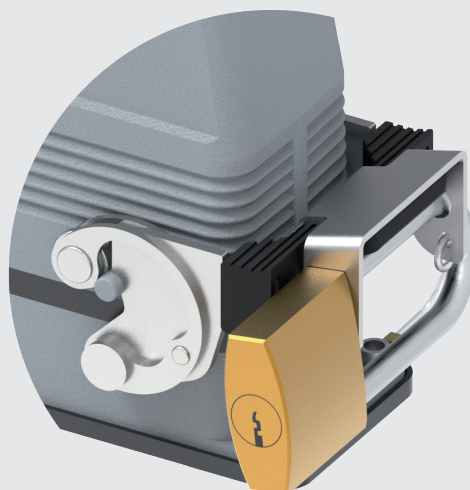

CR CLK CLASS lever lock device

enclosures

page:

CHI 10/16/24 poles + ⊕ 244, 250, 258
 CHP and MHP 10/16/24 poles + ⊕ 245, 251, 259

stainless steel locking device for two-lever housings

padlock, 40 mm arc clearance, optional

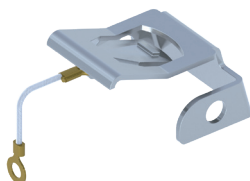

refer to CN.16 pages

FROM MARCH 2019

description

part No. (with eyelet)

part No.

stainless steel locking device, with eyelet, for fixing on the housings

CR CLK

padlock, supplied with 2 keys

TM BLC125

NOTE: Not suitable neither for hoods with locking levers and gasket nor for surface-mounting housings, high profile.

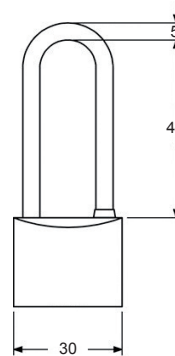
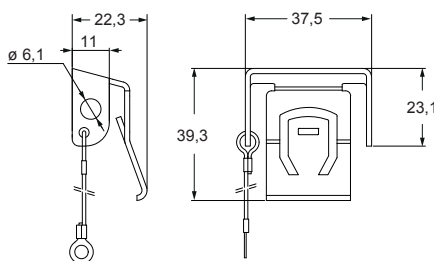

For fixing on housings

eyelet

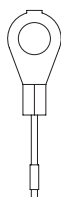

cURus pending

ASSEMBLY INSTRUCTIONS

CR CLK - LOCKING DEVICE INSERTION

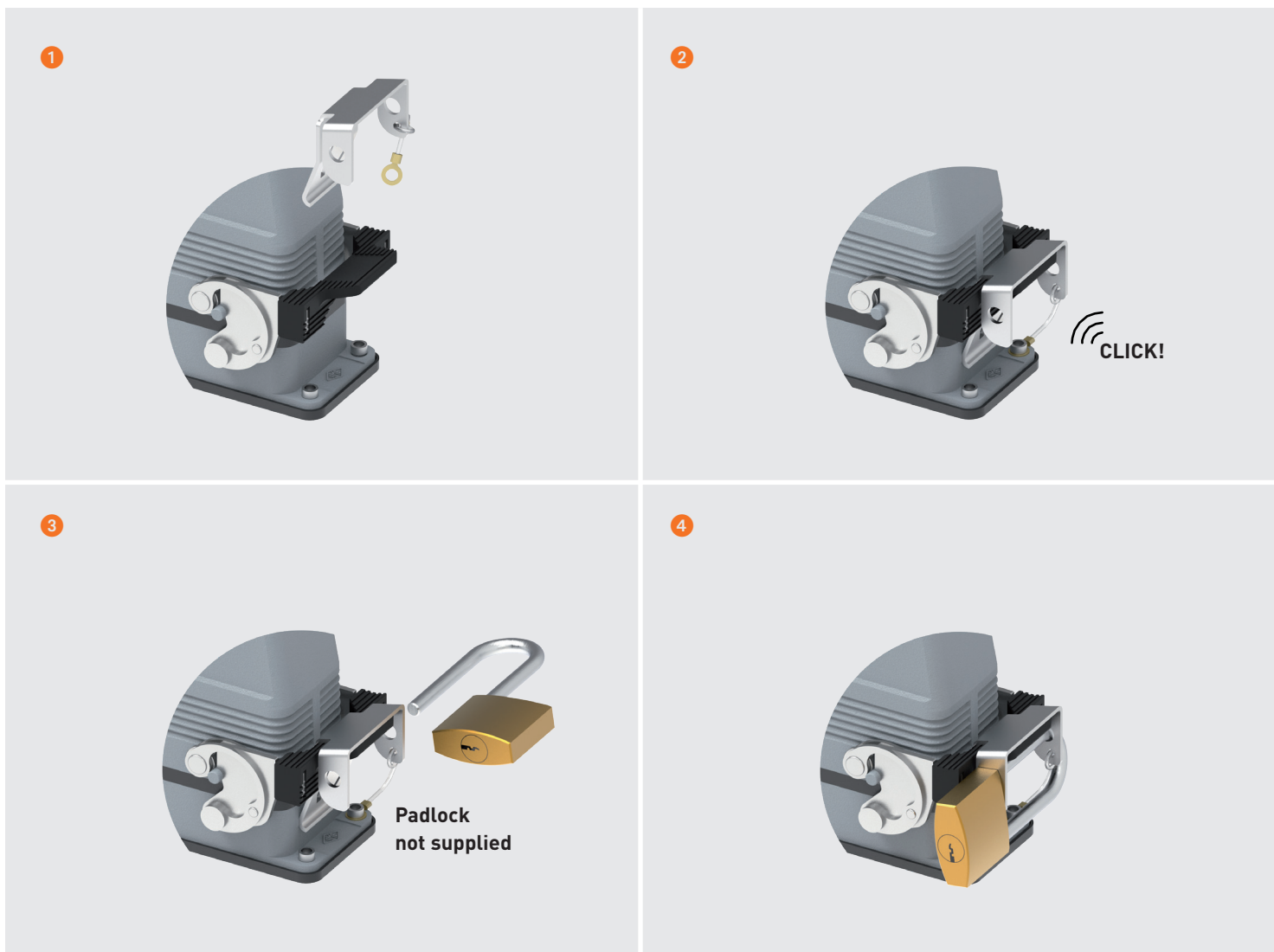

CR CLK - LOCKING DEVICE EXTRACTION

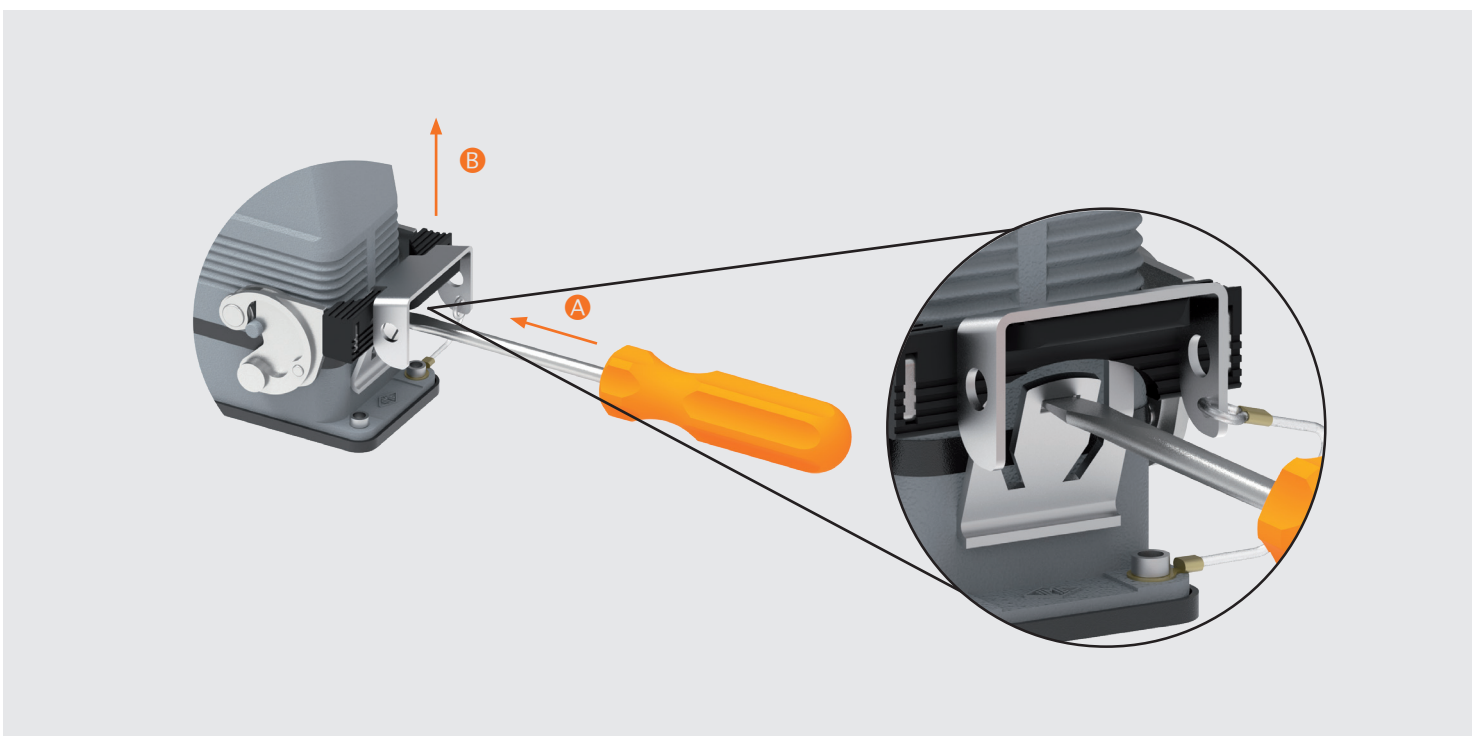

LOCKING DEVICE FOR ENCLOSURE SIZE "104.27" WITH CENTRAL LEVER



Locking device
for single stainless steel
central locking lever



Find more
information on
our products at
www.ilme.com

TECHNICAL FEATURES

CR YLK24 – CR YLK24 SL

- **locking device**, made in **stainless steel**, with **proprietary design**, that can be easily placed on the side of the central lever of a “104.27” hood in order to lock the opening movement of the locking lever, thus avoiding any unwanted and potentially hazardous accidental opening of the connector coupling under working condition;
- **possibility to apply, optionally, a padlock (CR BLC622**, separately available, 6 mm shackle diameter, 22 mm arc clearance) with **anti-tamper function**, to secure the locking against any unauthorized attempt to open the locking lever and disconnect the connector coupling;
- **two versions available:**
 - with eyelet cord end, **CR YLK24** for the fastening to a housing of a central lever coupling when not in use;
 - with “loop” cord end, **CR YLK24 SL** for the fastening to a hood when not in use (around the incoming cable).

CR YLK24 SL
locking device
with loop for
fixing on hoods

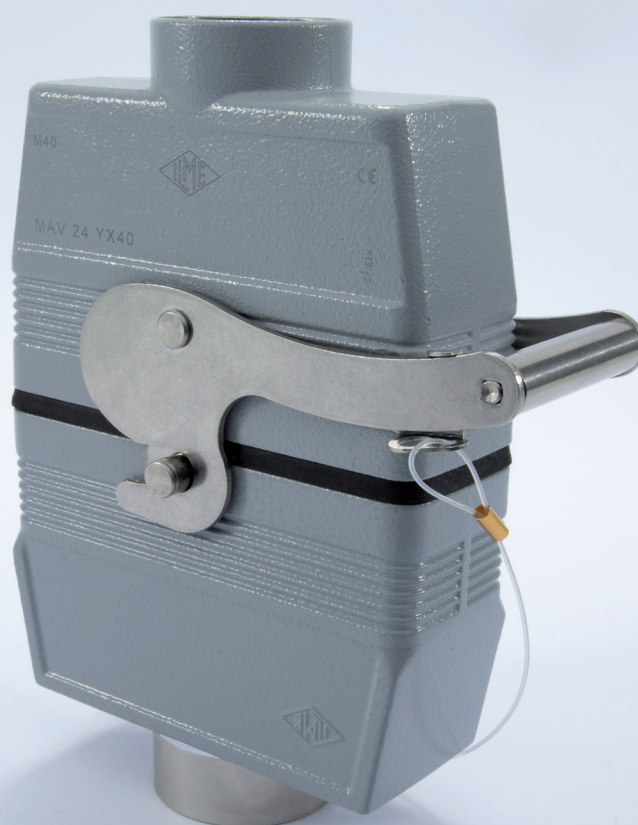

CR YLK24 – CR YLK24 SL

enclosures
central lever size "104.27"

page:
410 - 412

Locking device
for enclosure with central lever
size "104.27"



FROM APRIL 2019

Padlock, 22 mm arc clearance,
optional



refer to CN.16 pages

description	part No. (with eyelet)	part No. (with loop)	part. No.
locking device with eyelet for fixing on housings	CR YLK24		
locking device with loop for fixing on hoods		CR YLK24 SL	
padlock, supplied with 2 keys			CR BLC622

CR YLK24 and CR YLK24 SL

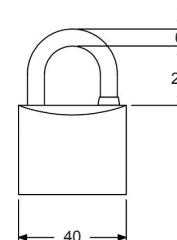
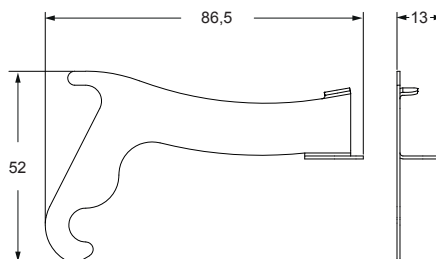

For fixing on housings

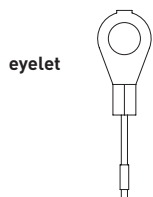

For fixing on hoods

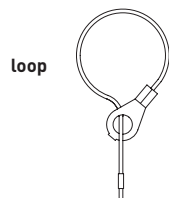

cURus pending

ASSEMBLY INSTRUCTIONS

CR YLK24 WITH EYELET

CABLE-TO-PANEL LOCKING

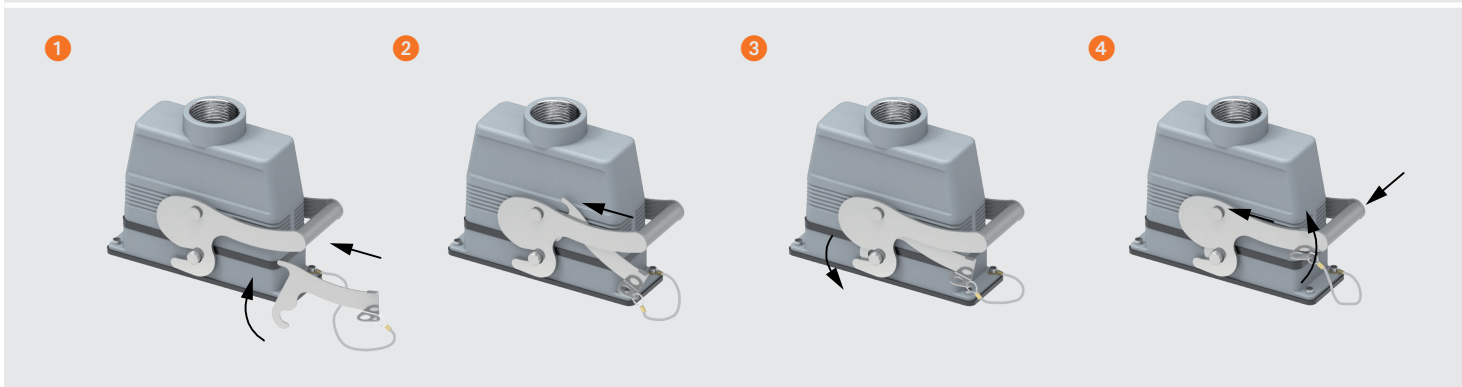

PADLOCK INSERTION

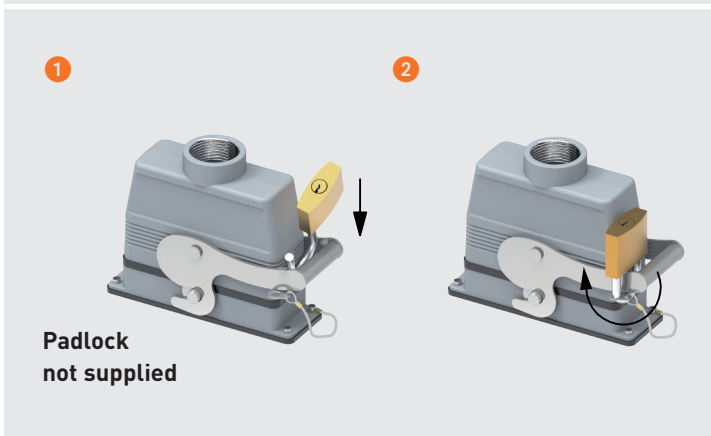

UNLOCKING

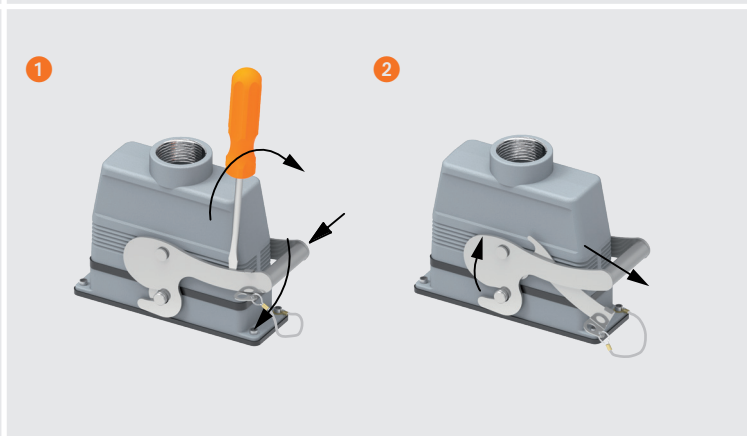

CR YLK24 SL WITH LOOP

CABLE-TO-CABLE LOCKING

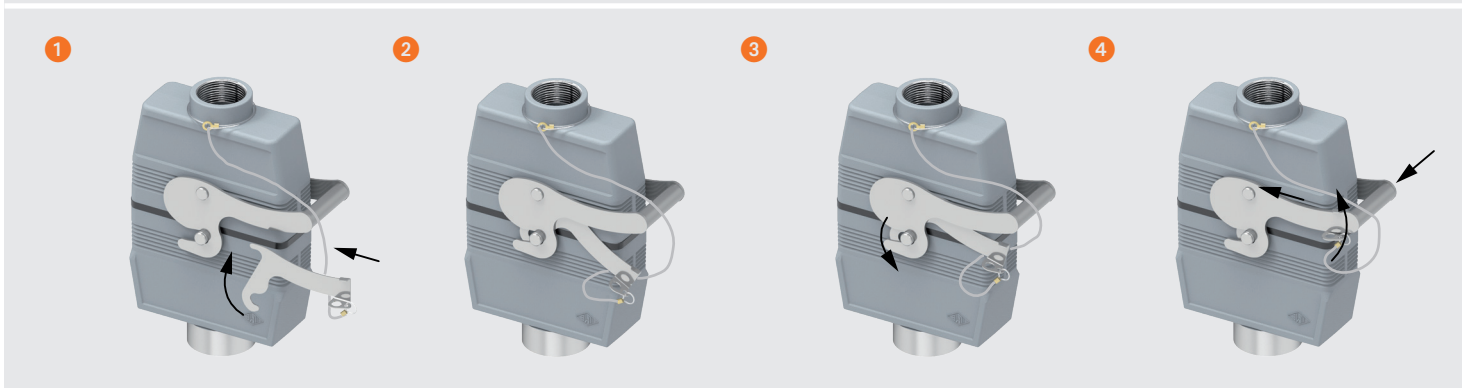

PADLOCK INSERTION

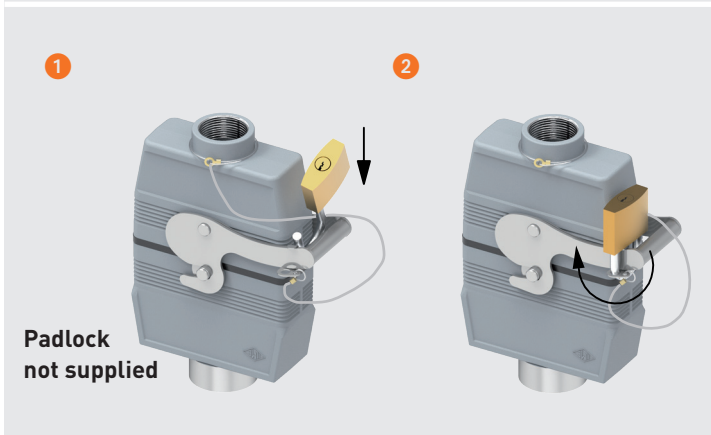

UNLOCKING

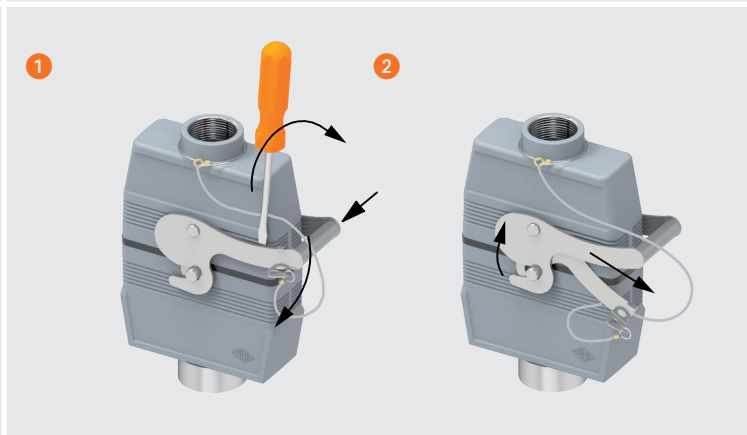

ANCHORAGES FOR MIXO FRAMES

CR 16 SSD - CR 24 SSD

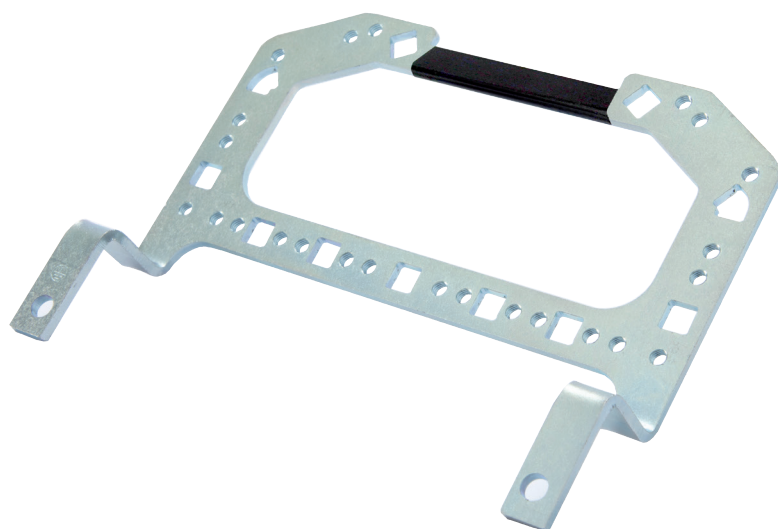

Anchorage
for off-axis fastening
made of zinc plated steel
sizes "77.27" and "104.27"



Find more
information on
our products at
www.ilme.com

TECHNICAL FEATURES

CR 16 SSD - CR 24 SSD

- intended for connecting to earth (protective bonding) several individual PE conductors and/or the screen of shielded cables;
- to be mounted on a correspondingly sized **MIXO frame** mounted on suitably sized **COB supports or docking frames CR ... DF** for a connector foreseen for use **without enclosures** (e.g. inside a control panel);
- made of **zinc plated steel** and available in sizes **"77.27"** and **"104.27"**;
- they can be used also in combination with **CR SP** supports for the installation on non-modular (i.e. non-MIXO) connector inserts (except for series CT, CTS and CTSE connector inserts);
- useful also for securing high diameter cables with **clamps**, in order to prevent the transmission of mechanical strain to the contacts;
- grip handle makes disconnection of the coupled connectors easier.

for off-axis
fastening,
for use without
enclosures,
e.g. inside a
control panel

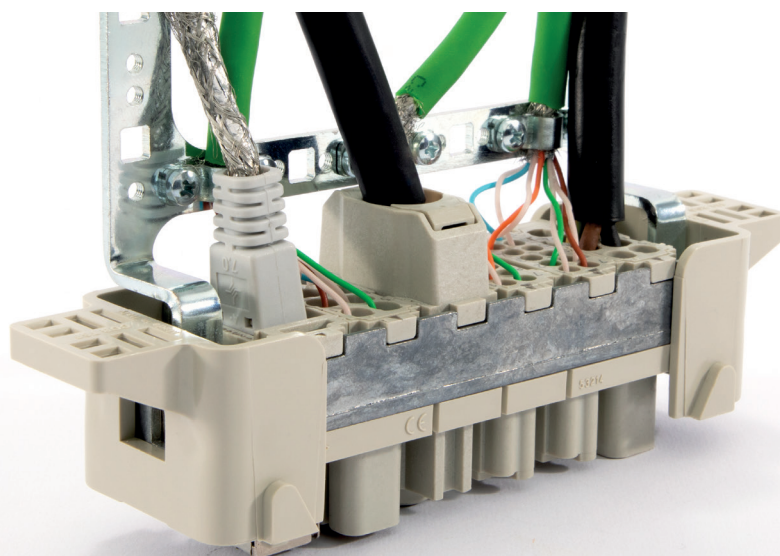

CR 16 SSD - CR 24 SSD

anchorage for cables outside enclosure, equipped with fixing screws and washers

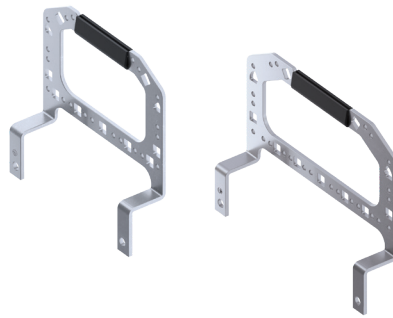

FROM FEBRUARY 2019

support, screws and clamps for grip panels of cables outside enclosure

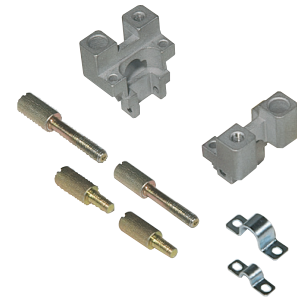

description

part No.

part No.

part No.

for cables, to be mounted on:
 inserts size "77.27"* with CR SP support
 and MIXO frames for 4 inserts without support
 inserts size "104.27"* with CR SP support
 and MIXO frames for 6 inserts without support
 support in die-cast zinc, 2 pcs. equipped with
 fixing screws and rings for earth connecting

CR 16 SSD

CR 24 SSD

CR SP

CR 26 V
CR 42 V

short screws in zinc plated steel, 2 pcs.
 long screws in zinc plated steel, 2 pcs.

to be mounted on CR..SS anchorage
 clamp for (shielded) cables \varnothing 5 mm
 clamp for (shielded) cables \varnothing 10 mm

CR 05 CA
CR 10 CA

* Except CT, CTS and CTSE

In the fixed part, a pair of **CR SP** supports is fitted on the connector insert, using the insert's fixing screws.
 A **CR..SSD** anchorage is then fitted on the **CR SP** supports, using the supplied fixing screws and washers.
 All parts are secured on the rear panel with a pair of **CR 26 V** special short screws.
 Also in the free part, a pair of **CR SP** supports is fitted on the connector insert and a **CR..SSD** anchorage is similarly secured on it. A pair of **CR 42 V** long screws fasten the free part to the fixed part.

NOTE: By unscrewing the **CR 26 V** special short screws, the whole assembly (free part + fixed part) can be removed from the panel for inspection.

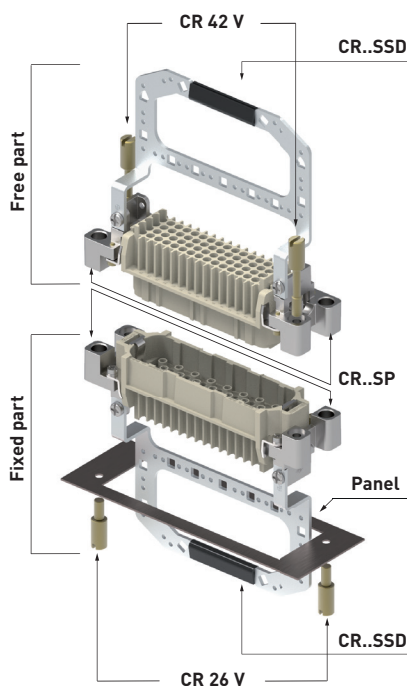

CR 16 SSD

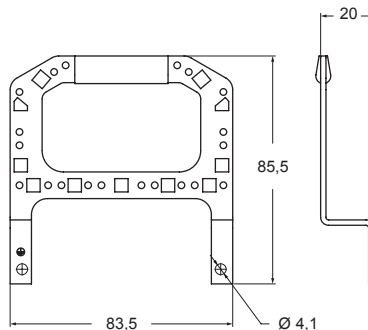

CR 24 SSD

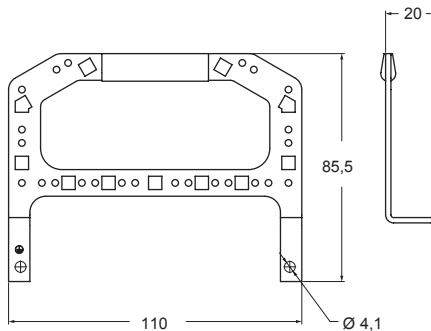

CR SP

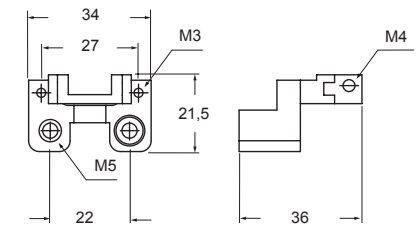

panel cut-out

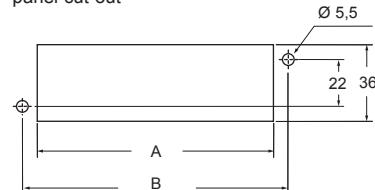

poles	06	10	16	24
A	52	65	85,5	112
B	65	78	98,5	125

CR 26 V

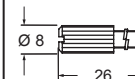

CR 42 V

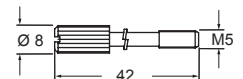

CR...CA

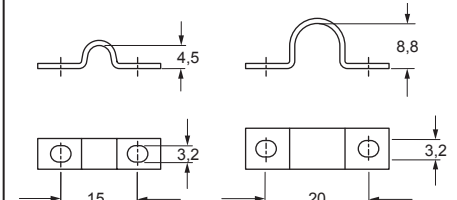

CR 24 SSD ANCHORAGE FOR MIXO FRAMES

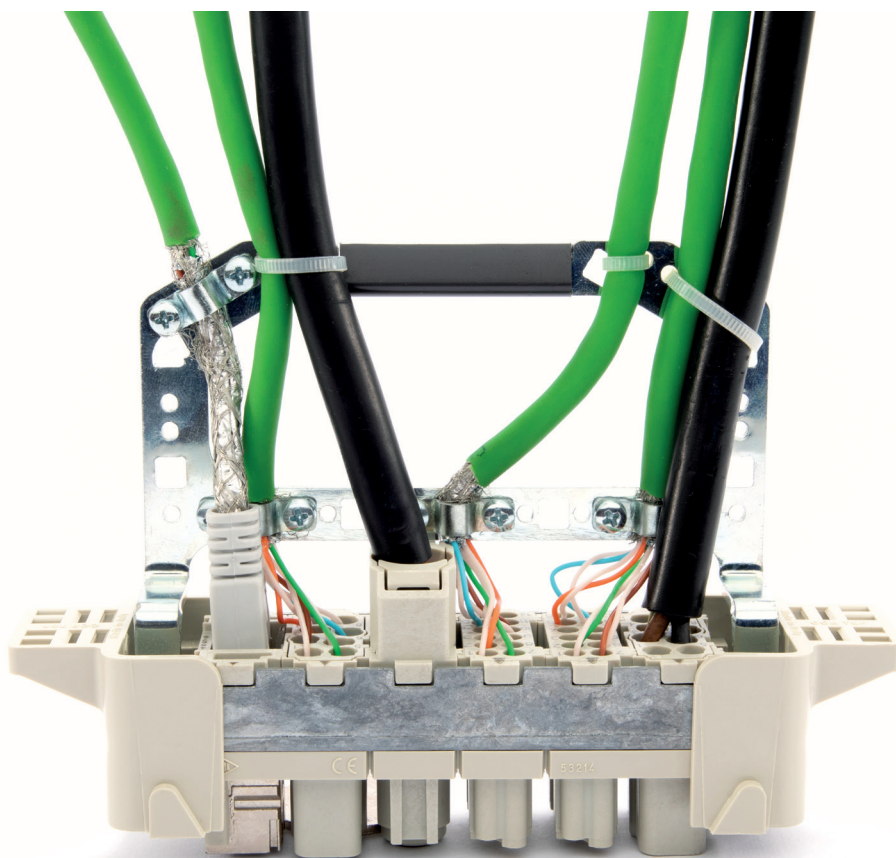

PE TERMINAL ADAPTERS FOR MIXO FRAMES

CGT 6.0 – CGT 10 - CGT 25



CGT 6.0
for small PE terminal
CGT 10 and CGT 25
for large PE terminal



Find more
information on
our products at
www.ilme.com

TECHNICAL FEATURES

CGT 6.0 – CGT 10 - CGT 25

- **PE terminal adapter CGT 6.0** made of nickel plated brass that allows to connect by crimping a 6 mm² / 10 AWG flexible copper conductor **to the small PE terminal** (2,5 mm² / 14 AWG) of a MIXO frame, in case the connector needs a second PE line sized 6 mm²/10 AWG when the large PE terminal (6 mm²/10 AWG) of the MIXO frame is already occupied by a large size PE conductor, by using the existing PE terminal adapter **CGT 16**, or the new ones for the large PE terminal, **CGT 10 or CGT 25**.
- **PE terminal adapters CGT 10 and CGT 25** made of nickel plated brass that allow to connect by crimping respectively a 10 mm² / 8 AWG or a 25 mm² / 4 AWG flexible copper conductor **to the large PE terminal** (6 mm²/10 AWG) of a MIXO frame.
- They are offered in addition to the existing PE terminal adapter **CGT 16** for 16 mm² / 6 AWG protective earth conductor - introduced with MIXO 100A modules **CX 02 G and CX 01 G** - to give more flexibility for the combination of MIXO 100A and 70A high power modules with **multi-core cables**, that have the PE conductor of the same size of the phase conductors.
- Crimping is achieved by using the already available manual hydraulic crimping tool **CGPZ** (Cembre HT 45) with hexagonal crimping dies **CGD 10 C** (for **CGT 10** with 10 mm² / 8 AWG and for **CGT 6.0** with 6 mm² / 10 AWG flexible copper conductors) and **CGD 25 C** (for **CGT 25** with 25 mm² / 4 AWG flexible copper conductors).

PE terminal adapters for small and large PE terminals

CGT 6.0



CGT 10



CGT 25

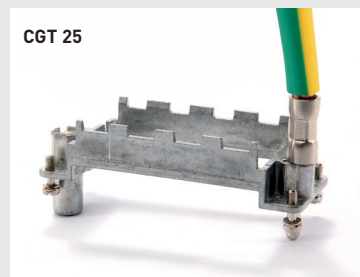

CGT 6.0 - CGT 10 - CGT 25

The modular inserts must be installed in suitable frames which are then mounted in traditional housings or COB panel support.

frames for modular units

page:
214 - 215

refer to CN.16 pages

PE terminal adapter

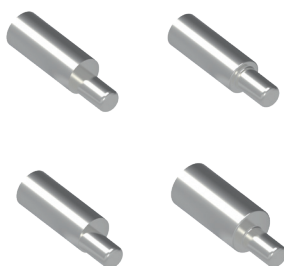

FROM FEBRUARY 2019

headless screw M4X6



description	part No.	part No.
PE wire terminal adapter 6 mm ² (10 AWG)	CGT 6.0	
PE wire terminal adapter 10 mm ² (8 AWG)	CGT 10	
PE wire terminal adapter 16 mm ² (6 AWG) *	CGT 16	
PE wire terminal adapter 25 mm ² (4 AWG)	CGT 25	
headless screw M4X6, stainless steel, kit of 10 pcs. (see point 5 below)		CR VGM4

How to use the PE terminal adapter

- Strip 15 mm of flexible PE wire.
- Crimp the cable on the CGT adapter by using the CGPZ pliers with the dies as follows:
 - **CGD 10 C** for 6 mm² and 10 mm²
 - **CGD 16 C** for 16 mm²
 - **CGD 25 C** for 25 mm²
- Fix the adapter tip in the larger earth terminal (6 mm²) for CGT 10, CGT 16, CGT 25 or in the smaller earth terminal (2,5 mm²) for CGT 6.0 of frames CX...TM/TF.
- To be used with bulkhead mounting housings or high construction hoods.
- Cannot be used with T-TYPE surface mounting housings and horizontal cable outlet hoods. For the use within bulkhead housings and vertical entry hoods it is needed to replace the M4 screw of the 6 mm² PE contact of the frame with the headless screw **CR VGM4**.

* CGT 16 already available

CGT 6.0

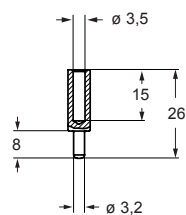

CGT 10

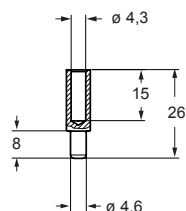

CGT 16

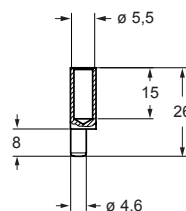

CGT 25

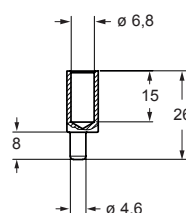

cURus pending

CGT 25 PE TERMINAL ADAPTERS FOR MIXO FRAMES

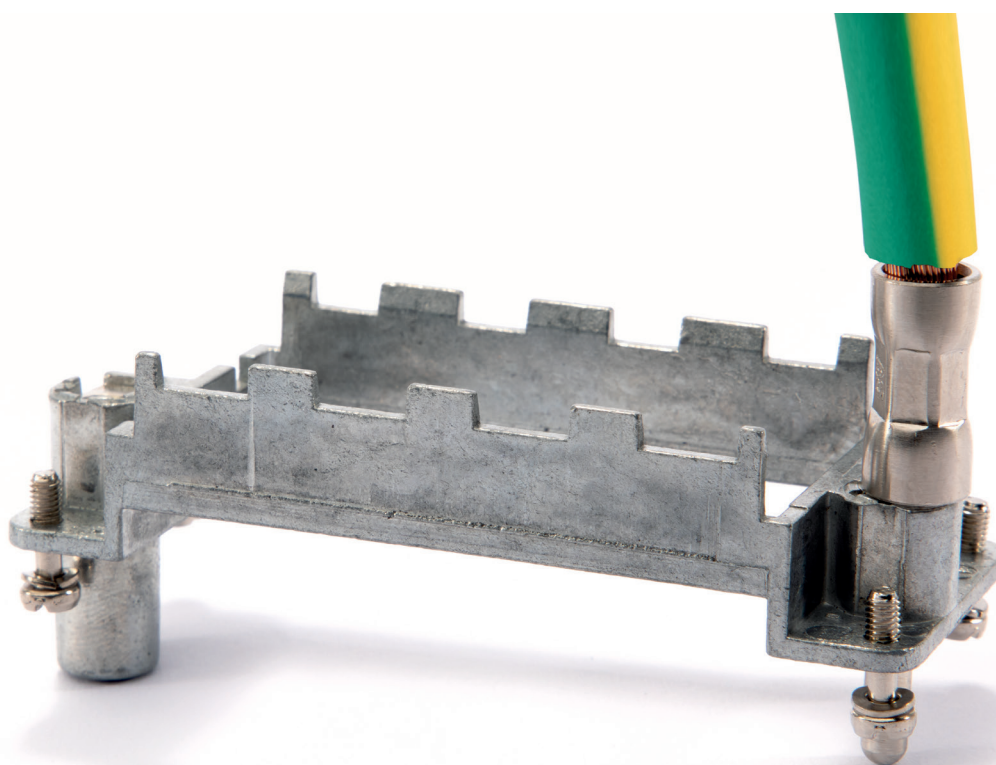

RJ45 UNIVERSAL PATCH CORD ADAPTER CJK 8M

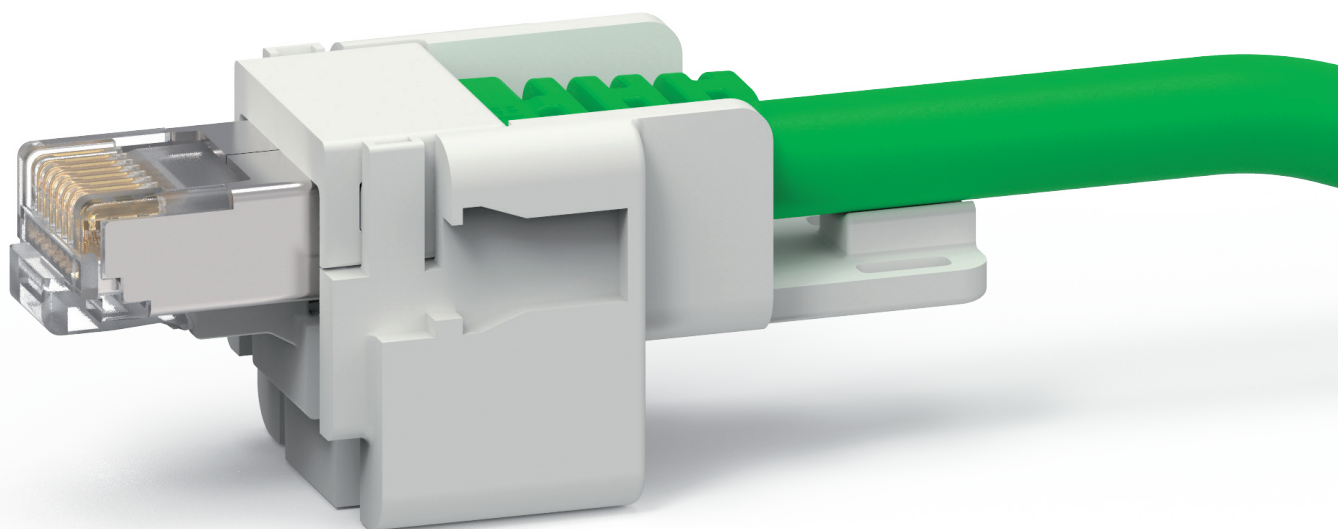

CJK 8M
RJ45 universal patch
cord adapter



Find more
information on
our products at
www.ilme.com

TECHNICAL FEATURES

CJK 8M

- **CJK 8M** adapter insert size “21.21” for placing an RJ45 plug (male connector) of a pre-assembled patch cord into a **M25** size “21.21” top cable entry hood, either metal or insulating;
- it allows a **truly “universal”** use thanks to the possibility to install virtually any RJ45 patch cord plugs available on the market (of any Category: Cat. 5, 5e, 6, 6A, 7, or 8) inside the growing range of size “21.21” top entry hoods with glued gasket, **without any disassembly of the patch cord**. A straightforward smart solution, all the more so if compared with more complex and expensive solutions;
- the **proprietary ILME design** of this adapter foresees a **two-part insulating carrier** (the first part acting as **carrier**, the second as **latch**) that can quickly and easily make captive the RJ45 plug (male connector), the assembly is then introduced in the relevant “21.21” M25 top entry hood and fastened to it by the usual screw;
- a **metallic** (nickel plated brass) **or insulating** (light grey or black colour) **M25 cable gland** with suitable internal diameter to let the patch cord RJ45 plug pass-through **is separately available**;
- the **special sealing gasket**, provided with the RJ45 adapter **CJK 8M**, is **longitudinally cut** on its flank and must be applied over the cable to increase its diameter in the portion to introduce in the cable gland sealing, according to instructions;
- suitable for the combination of an RJ45 patch cord with one or both RJ45 plug extremities mounted inside suitable size “21.21” *insulating or metal* M25 top entry hood with glued gasket, with an RJ45 jack counterpart (female connector), e.g. a **CJ KF** adapter combined with the relevant female/female RJ45 connector **CX 8 JF** or **CX 8/2 JF** (4-way version **CX 4 JF** or 4/2-way version **CX 4/2 JF** are available upon request), mounted inside a corresponding counterpart hood or housing with locking lever size “21.21”;
- optional four coding positions with **CR KC** insert coding pin (4 pins required for each connector coupling).

equipped
with a special
longitudinally cut
sealing gasket

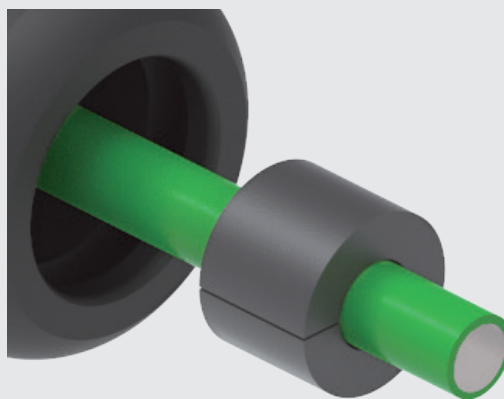

CJK 8M

enclosures:
size "21.21"

MKG V25
MKAG V25
MKG VN25

page: **RJ45
universal patch cord adapter**

75
-
75

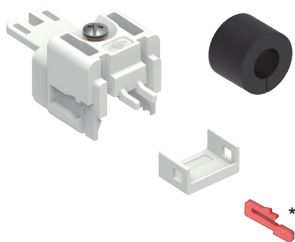

FROM APRIL 2019

**M25
cable gland**



FROM APRIL 2019

description	part No	part No.	entry M
universal patch cord adapter	CJK 8M		
insert coding pin for RJ45 adapters (optional)*	CR KC		
plastic cable gland, light grey (RAL 7035)		AW M25IJ	25
plastic cable gland, black (RAL 9005)		AW M25INJ	25
nickel plated brass cable gland		AW M25PJ	25

* Optional four coding positions with **CR KC** insert coding pin (4 pins required for each connector coupling).

**How to use CR KC coding pins
(cannot be used with IP68 enclosures)**

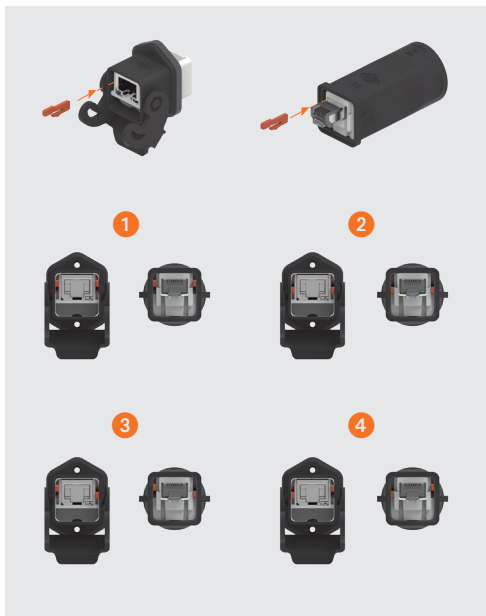

CJK 8M

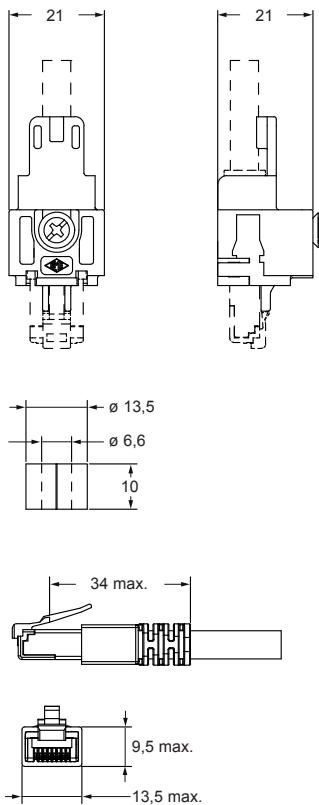

CR KC

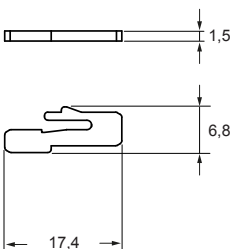

AW M25IJ and AW M25INJ

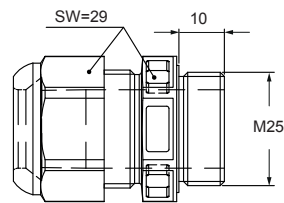

AW M25PJ

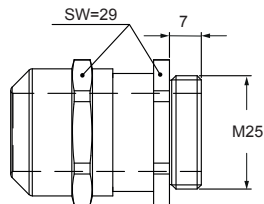

cURus pending

ASSEMBLY INSTRUCTIONS

CJK 8M



Watch our online tutorial

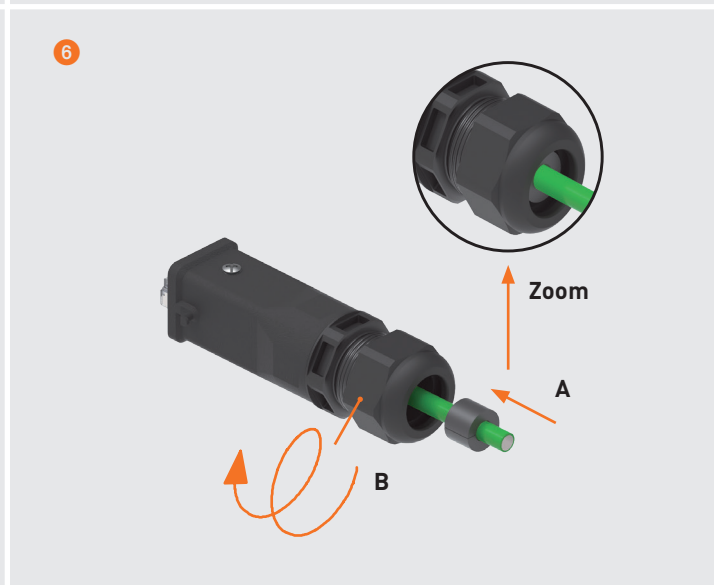
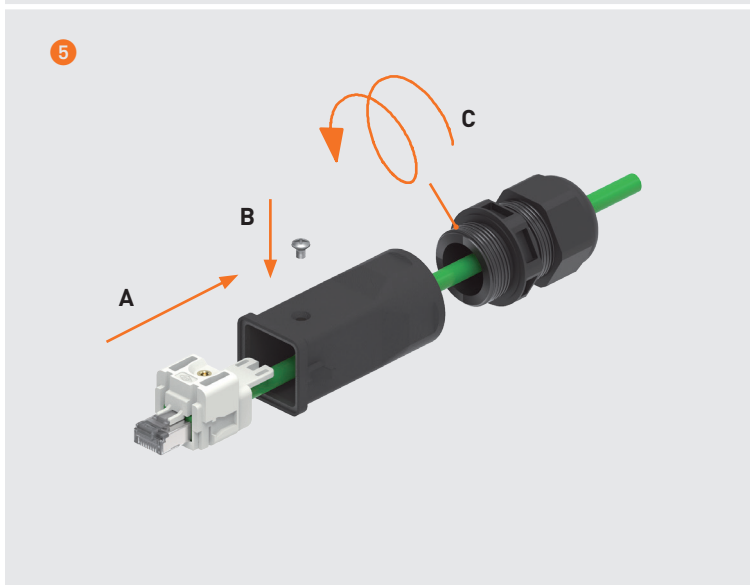
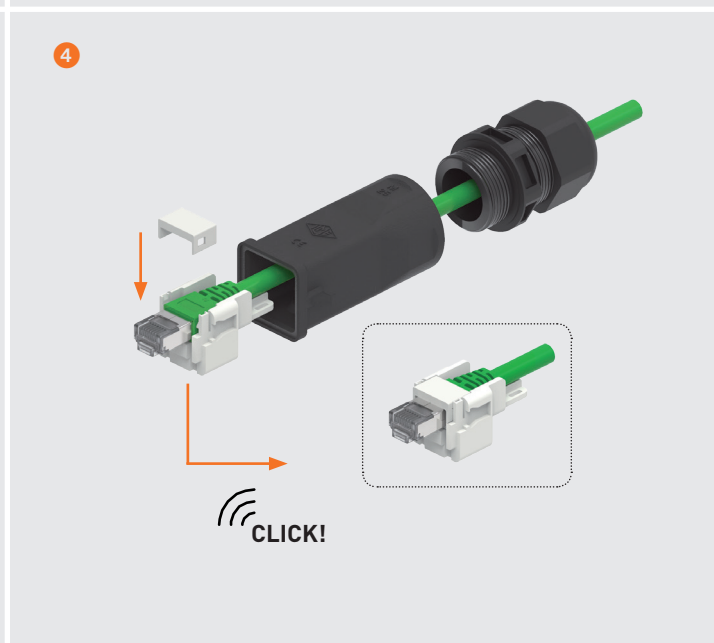
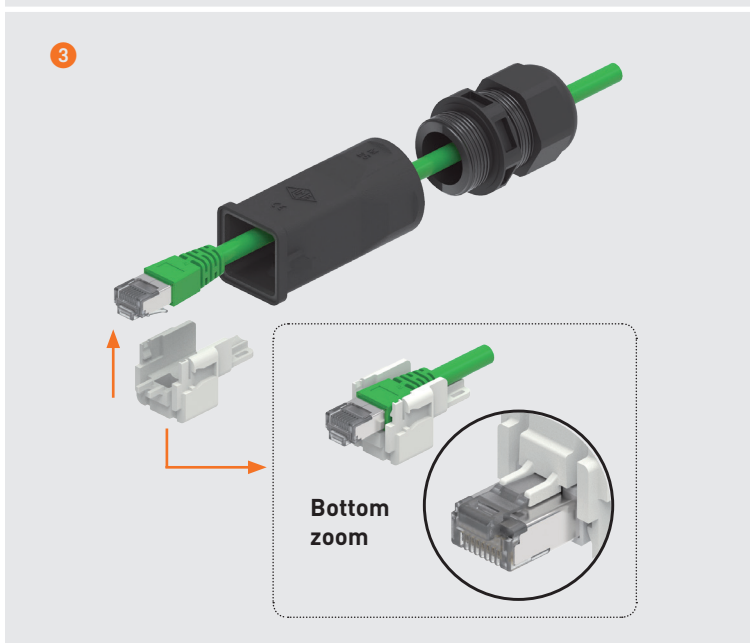
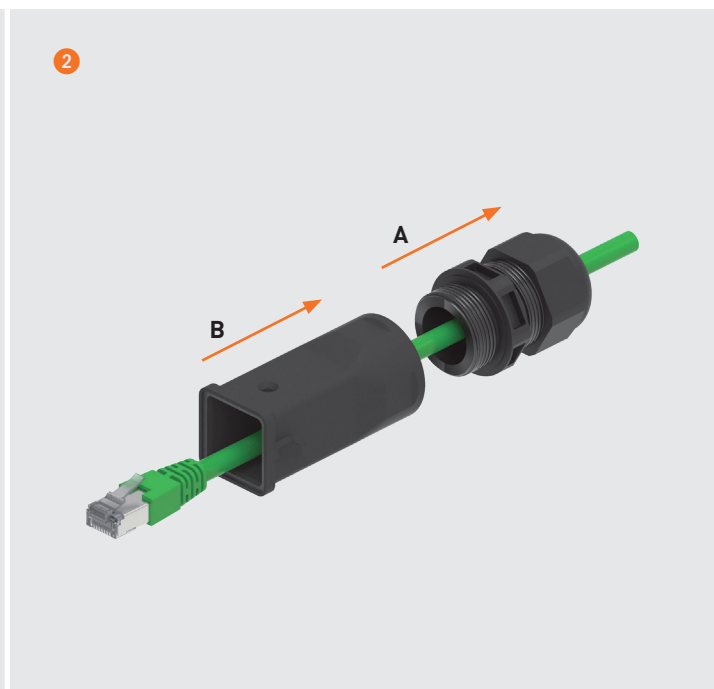
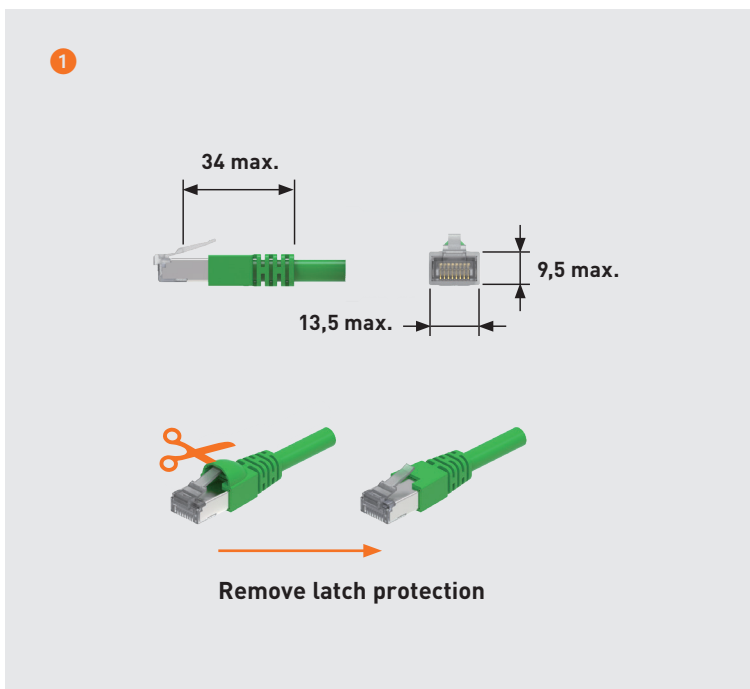

HYGIENIC CABLE GLANDS AH M25IF(L) - AH M32IF(L)



Cable glands for food industry
- IP68/IP69 degree of protection
- according to EHEDG guidelines



Find more
information on
our products at
www.ilme.com

TECHNICAL FEATURES

AH M25IF(L) - AH M32IF(L)

- cable glands made in materials approved for the use in the food industry, with degree of protection **IP68/IP69**;
- designed and certified in accordance with the **EHEDG** guidelines;
- they are resistant to the most common cleaning products (disinfectants, acids, alkalis and condensates) used in the food industry;
- good complement of T-TYPE /H Hygienic enclosures;
- for each thread size (M25 and M32) these glands are available in **two versions, each suitable for a different range of cable diameters**;
- temperature range **-20 °C ... +85 °C** (special versions with extended range -40 °C ... +85 °C available upon request).

designed
and certified
in accordance
with the EHEDG
guidelines

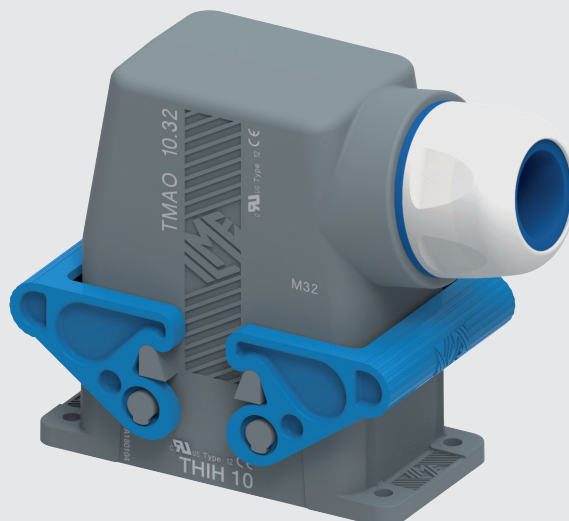

AH M25IF(L) - AH M32IF(L)

enclosures:
HYGIENIC T-TYPE / H IP66/IP69
(only M25 or M32)

page:
350 - 357

HYGIENIC M25 cable gland



FROM FEBRUARY

HYGIENIC M32 cable gland

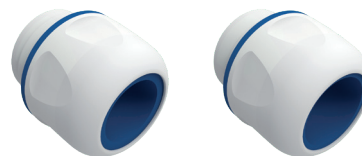

FROM FEBRUARY

refer to CN.16 pages

description	part No.	entry M	part No.	entry M
cable glands M25X1,5 for cable \varnothing 12,0-15,0 for cable \varnothing 15,0-18,0	AH M25IF AH M25IFL	M25 M25	AH M32IF AH M32IFL	M32 M32

NOTE: For details about their installation refer to the instruction sheet accompanying the product:

- ECOLAB compliant
- EHEDG compliant
- IP68, IP69 degree of protection
- ambient temperature limit: -20 °C ... +85 °C
- cURus (UL Recognized Component for USA and Canada), cULus (UL Listed Product for USA and Canada), EAC certifications

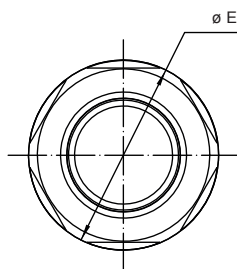
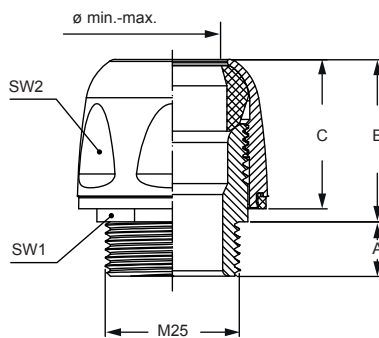

part No.	A	B	C	SW1	SW2	\varnothing E	\varnothing min.-max.
AH M25IF	10	30	27	24	32	34,9	12,0-15,0
AH M25IFL	10	30	27	24	32	34,9	15,0-18,0

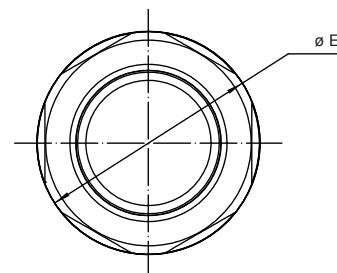
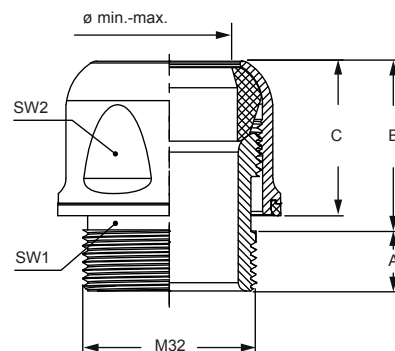

part No.	A	B	C	SW1	SW2	\varnothing E	\varnothing min.-max.
AH M32IF	11	32	28	30	38	40,9	18,0-21,0
AH M32IFL	11	32	28	30	38	40,9	20,0-23,0

HYGIENIC CABLE GLANDS



A

AH M25IF	130
AH M25IFL	130
AH M32IF	130
AH M32IFL	130
AW M25IJ	126
AW M25INJ	126
AW M25PJ	126

C

CAV 06 GYC21	92
CAV 06 GYC29	92
CAV 10 GYC21	93
CAV 10 GYC29	93
CAV 16 GYC21	94
CAV 16 GYC29	94
CAV 24 GYC21	95
CAV 24 GYC29	95
CDFA 0.3	48*
CDFA 0.5	48
CDFA 0.7	48*
CDFA 1.0	48
CDFA 1.5	48*
CDFA 2.5	48*
CDFD 0.3	48*
CDFD 0.5	48*
CDFD 0.7	48*
CDFD 1.0	48*
CDFD 1.5	48*
CDFD 2.5	48*
CDMA 0.3	48*
CDMA 0.5	48*
CDMA 0.7	48*
CDMA 1.0	48
CDMA 1.5	48*
CDMA 2.5	48*
CDMD 0.3	48*
CDMD 0.5	48*
CDMD 0.7	48*
CDMD 1.0	48*
CDMD 1.5	48*
CDMD 2.5	48*
CFV 06 GYC21	92
CFV 06 GYC29	92
CFV 10 GYC21	93
CFV 10 GYC29	93
CFV 16 GYC21	94
CFV 16 GYC29	94
CFV 24 GYC21	95

CFV 24 GYC29	95
CGT 6.0	122
CGT 10	122
CGT 16	122
CGT 25	122
CHIX 32 L	98
CHIX 32 LP	98
CHIX 32 LS	98
CHPX 32 L	99
CHPX 32 L29	99
CHPX 32 LP29	99
CHPX 32 LP36	99
CHPX 32 LS	99
CHPX 32 LS29	99
CJK 8M	126
CKR 65	60*
CKR 65 D	60*
CQ4F 02	32
CQ4F 02 H	33
CQ4M 02	32
CQ4M 02 H	33
CR 05 CA	118
CR 10 CA	118
CR 16 SSD	118
CR 24 SSD	118
CR 26 V	118
CR 42 V	118
CR BLC622	114
CR CLK	110
CR CX01B	56
CR CX01G	56
CR CX01N	56
CR CX01R	56
CR KC	126
CR Q02	34
CR SP	118
CR VGM4	122
CR YLK24	114
CR YLK24 SL	114
CSHF 06 S	16
CSHF 10 S	17
CSHF 16 S	18, 20
CSHF 16 SN	20
CSHF 24 S	19, 21
CSHF 24 SN	21
Cshm 06 S	16
Cshm 10 S	17
Cshm 16 S	18, 20
Cshm 16 SN	20
Cshm 24 S	19, 21
Cshm 24 SN	21
CVAP 06LSP21	102

CVAP 06LSP29	102
CVAP 10LSP21	103
CVAP 10LSP29	103
CVAP 16LSP21	104
CVAP 16LSP29	104
CVAP 24LSP21	105
CVAP 24LSP29	105
CVP 06 LSP16	102
CVP 10 LSP16	103
CVP 16 LSP21	104
CVP 24 LSP21	105
CX 01 T	45
CX 02 TF	49
CX 02 TM	49
CX 03 TF	49
CX 03 TM	49
CX 04 TF	49
CX 04 TM	49
CX 05 SHF	44
CX 05 SHM	44
CX 06 TF	49
CX 06 TM	49
CX 42 DF	48, 50
CX 42 DM	48, 50
CXA 01 I	54
CXFA 1.5	32, 33
CXFA 2.5	32, 33
CXFA 4.0	32, 33
CXFA 6.0	32, 33
CXFA 10	32, 33
CXMA 1.5	32, 33
CXMA 2.5	32, 33
CXMA 4.0	32, 33
CXMA 6.0	32, 33
CXMA 10	32, 33
CXP 01 C	55
CXP 01 CLG	55
CZAP 25LSP16	107
CZAP 25LSP21	107
CZP 15 LSP16	106
CZP 15 LSP21	106

J

JSHF 06 S	24
JSHF 10 S	25
JSHF 16 NS	28
JSHF 16 S	26, 28
JSHF 24 NS	29
JSHF 24 S	27, 29
JSHM 06 S	24
JSHM 10 S	25
JSHM 16 NS	28

* These items are also shown in various sections throughout the catalogue

JSHM 16 S	26, 28
JSHM 24 S	27, 29

M

MAV 06 GYC25	92
MAV 06 GYC32	92
MAV 06 GYC40	92
MAV 10 GYC25	93
MAV 10 GYC32	93
MAV 10 GYC40	93
MAV 16 GYC25	94
MAV 16 GYC32	94
MAV 16 GYC40	94
MAV 24 GYC25	95
MAV 24 GYC32	95
MAV 24 GYC40	95
MFV 06 GYC25	92
MFV 06 GYC32	92
MFV 06 GYC40	92
MFV 10 GYC25	93
MFV 10 GYC32	93
MFV 10 GYC40	93
MFV 16 GYC25	94
MFV 16 GYC32	94
MFV 16 GYC40	94
MFV 24 GYC25	95
MFV 24 GYC32	95
MFV 24 GYC40	95
MGK V25	88
MGK V25 B	89
MHPX 32 L40	99
MHPX 32 LP40	99
MHPX 32 LP50	99
MHPX 32 LS40	99
MKA IF	61
MKAS IF	65
MKAS IVG20	71
MKAS VG25	85
MKA VG25	81
MKAX IF	60
MKAXR IF	66
MKAXS IF	64
MKAXS IVG20	70
MKAXS VG25	84
MKAX VG25	80
MKAXW IF	62
MKAXW VG25	82
MKAXX IF	61
MKAXXR IF	67
MKAXXS IF	65

MKAXXS IVG20	71
MKAXXS VG25	85
MKAXX VG25	81
MKAXXW IF	63
MKAXXW VG25	83
MKG V25	75
MKG VN25	75
MK V25	74
MK VG25	76
MK VGN25	77
MK VN25	74
MVAP 06LSP25	102
MVAP 06LSP32	102
MVAP 06LSP40	102
MVAP 10LSP25	103
MVAP 10LSP32	103
MVAP 10LSP40	103
MVAP 16LSP25	104
MVAP 16LSP32	104
MVAP 16LSP40	104
MVAP 24LSP25	105
MVAP 24LSP32	105
MVAP 24LSP40	105
MVP 06 LSP20	102
MVP 10 LSP20	103
MVP 10 LSP25	103
MVP 16 LSP25	104
MVP 24 LSP25	105
MXA 01 O25	54
MXA 01 V25	54
MXA 01 V32	54
MZAP 25LSP20	107
MZAP 25LSP25	107
MZP 15 LSP20	106
MZP 15 LSP25	106

R

RDF2D 0.3	38, 50
RDF2D 0.5	38, 50
RDF2D 0.7	38, 50
RDF2D 1.0	38, 50
RDF2D 1.5	38, 50
RDF2D 2.5	38, 50
RDM2D 0.3	38, 50
RDM2D 0.5	38, 50
RDM2D 0.7	38, 50
RDM2D 1.0	38, 50
RDM2D 1.5	38, 50
RDM2D 2.5	38, 50
RX 02 TF	51

RX 02 TM	51
RX 03 TF	51
RX 03 TM	51
RX 04 TF	51
RX 04 TM	51
RX 06 TF	51
RX 06 TM	51
RXF2D 1.5	38
RXF2D 2.5	38
RXF2D 4.0	38
RXF2D 6.0	38
RXF 12/2	38
RXM2D 1.5	38
RXM2D 2.5	38
RXM2D 4.0	38
RXM2D 6.0	38
RXM 12/2	38

T

TM BLC125	110
-----------------	-----

Visit ilme.com and watch our Configurator video to discover how easy is to design your connector in real time.

Get into ILME Configurator

Design your own connector in real time

Search, choose, download!

Welcome to ILME

Watch our configurator movie

Ilme Smart Configurator is a dynamic tool to digital access and match our database of over 7.000 product codes.



search

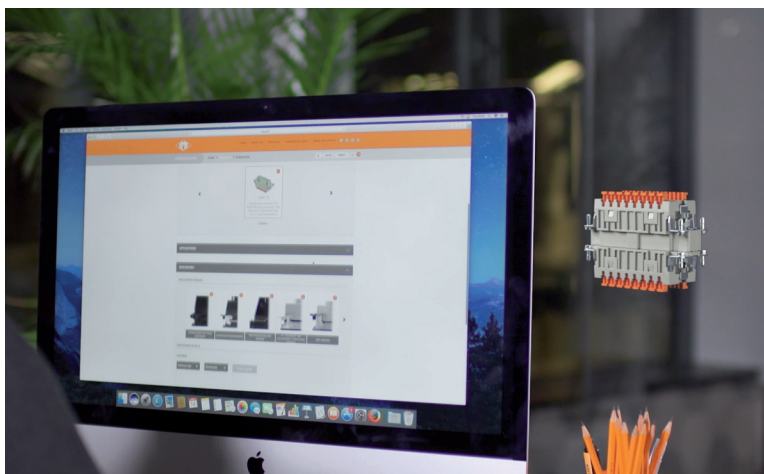

Over 50 million of online connector combinations.

choose

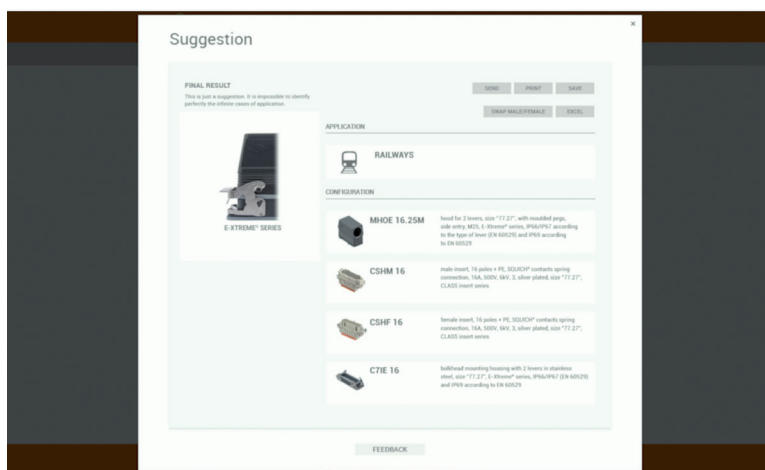

Easy selection of individual parts for key applications and recommendations for custom environmental conditions.

download

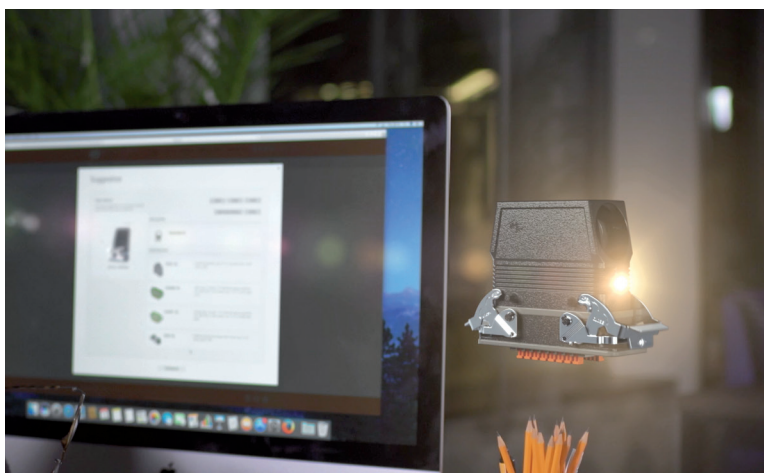

Smart suggestion to get the most suitable configuration.

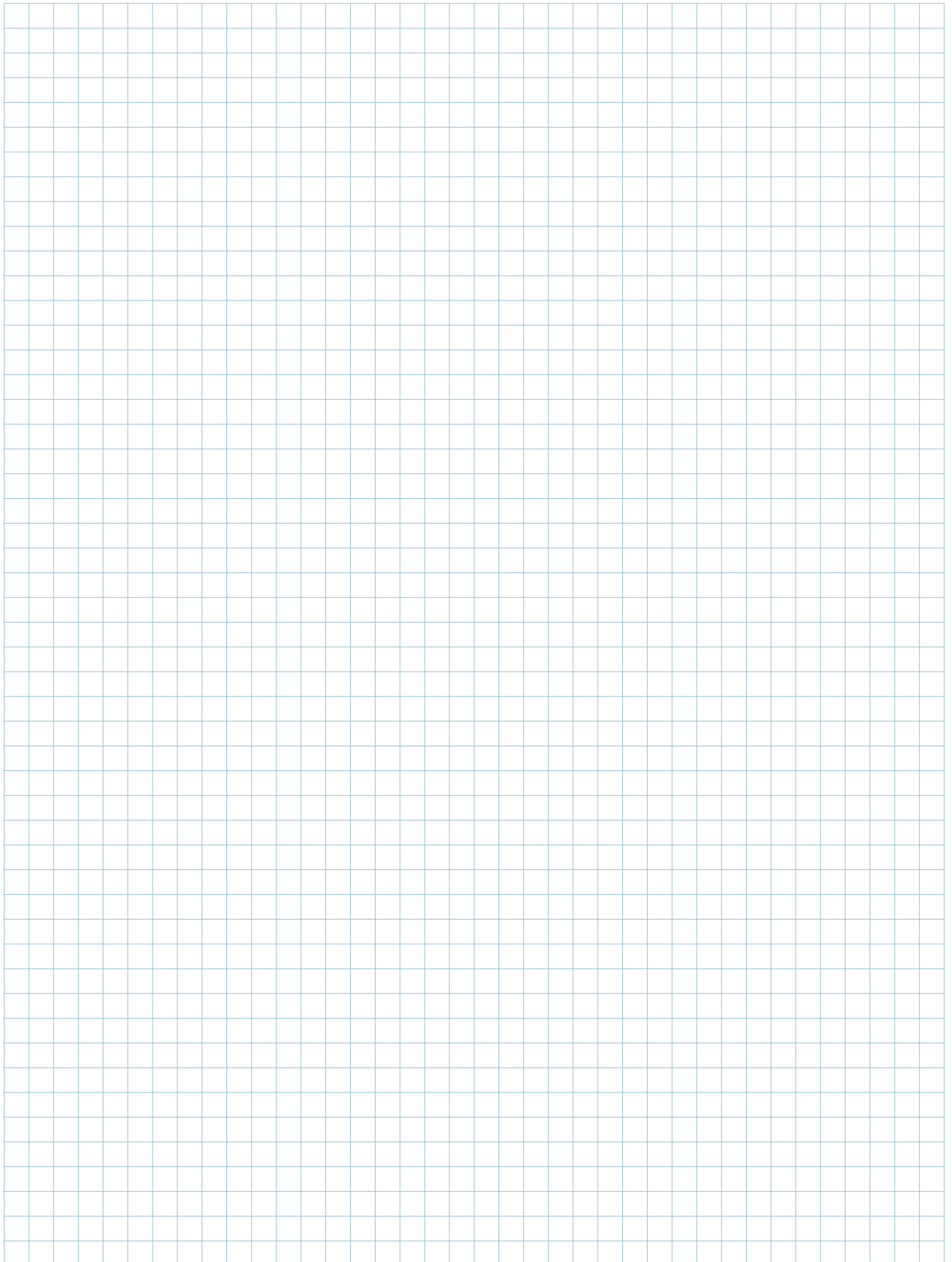



Worldwide Sales Organization

Headquarters	ILME S.p.A. Via M.A. Colonna, 9 20149 Milano, Italia T +39 0234560522 info@ilme.com
France	ILME FRANCE S.A.R.L. Rue Roland Garros Parc d'Activités de l'Aéroport 42160 Andrézieux-Bouthéon T +33 04 7736 2336 ilme-france@ilme.fr
Germany	ILME GmbH Max-Planck-Straße 12 51674 Wiehl T +49 (0)2261 7955 0 technik@ilme.de
Sweden and Nordic Countries	ILME NORDIC AB Transportvägen 18 246 42 Löddeköpinge T +46 4618 2800 info@ilme.se
United Kingdom	ILME UK LIMITED 50 Evans Road, Venture Point Speke, Liverpool L24 9PB T +44 0151 336 9321 sales@ilmeuk.co.uk
China	ILME CHINA CO. LTD. Room 101, Building 3, 188 Xinjunhuan Road, Minhang Shanghai 201114 T +86 21 6248 9961 info@ilmechina.com
Japan	ILME JAPAN CO. LTD. K.I.B.C. Bldg 5-2, Minatojima Minamimachi 5-Chome, Chuo-Ku, Kobe 650-0047 T +81 78 302 2005 info@ilmejapan.co.jp

www.ilme.com



ILME S.p.A.
Via M.A. Colonna 9
20149 Milano, Italy
www.ilme.com

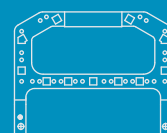
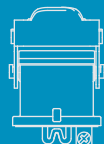
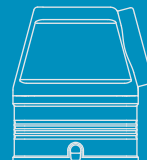
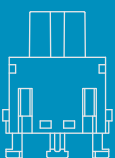
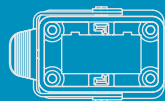
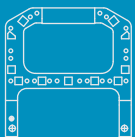
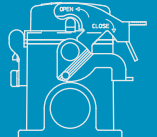
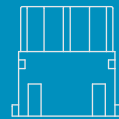
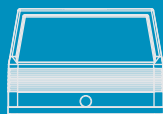
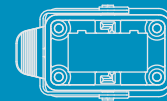
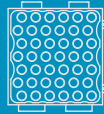
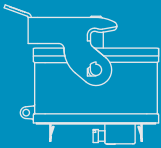
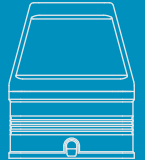
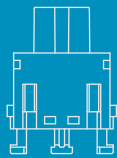
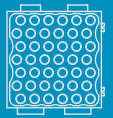
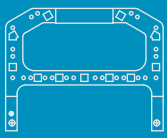
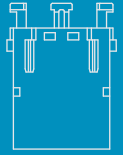
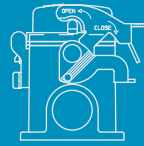
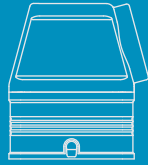
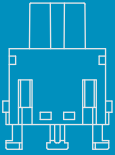
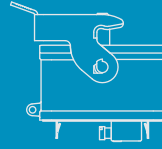
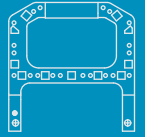
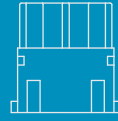
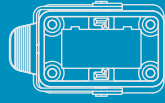

XDGPDT19 519



catalogues